

# 17"-32" display Gas spring dual monitor arm

**DELTA**  
A NORDIC BRAND  
**OFFICE**

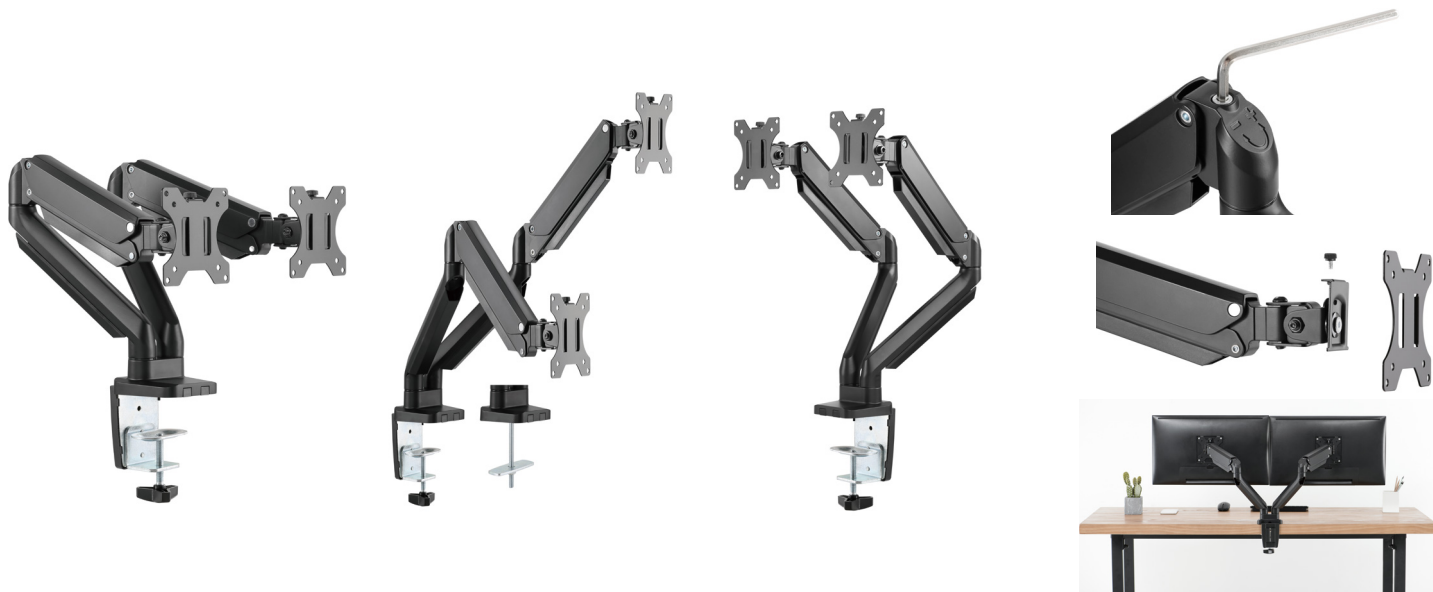

## PRODUCT DATA

Compatible displays:	17"-32"
Screen quantity:	2
Weight capacity (per screen):	1.5~8 kg
VESA:	75x75, 100x100
Product category:	Gas spring monitor arm
Tilt range:	+45°~-45°
Swivel range:	+90°~-90°
Screen rotation:	+180°~-180°
Material:	Aluminum, plastic, steel
Surface finish:	Powder coating
Color:	Matte black
Dimensions:	944x125x590mm (37.2"x4.9"x23.2")
Arm full extension:	445mm (17.5")
Suggested desktop thickness:	Clamp:10~85mm grommet:10~85mm (clamp:0.39"~3.3" grommet:0.39"~3.3")
Installation:	Grommet, clamp
Fit curved monitor:	Yes
Cable management:	Yes
Quick release VESA plate:	Yes
Accessory kit package:	Normal/ziplock, polybag, compartment polybag

## LOGISTICS DATA

Article number:	ARM-0351
Brand:	DELTA
EAN code:	7333048042781
Country of origin:	China
Custom tariff number:	83024900
Master carton packing unit:	4
Master carton gross weight:	20.42 kg
Master carton dimensions:	63 x 42 x 28 cm
Package type:	Box
Package weight:	5.03 kg
Package dimensions:	40.5 x 30.5 x 13.1 cm

## PACKAGING

Package contents:	Desk mount, mounting kit and manual
-------------------	-------------------------------------

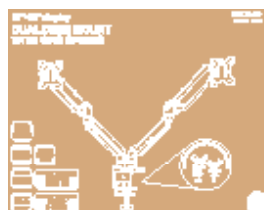

-Image may differ from the actual package

## Drawing

