

CALPEX Low Temperature System

Flexibly towards a safe future



NEW: CALPEX PLUS
22% improved
insulation

Contents

Utilise your advantages	3–4
System description	5–6
Pressure loss	7
Heat loss	8– 9
Heating range	10–21
Dimension of pipe UNO/DUO	10
House entry bend	11
Forked pipe	12
Sealing ring	13
End cap	13–14
Screw connection	15–17
Press connection	18–20
Electrofusion fitting	21
Sanitary range	22–29
Dimension of pipe UNO/DUO	22
House entry bend	23
Sealing ring	24
End cap	24–25
Screw connection	25–26
Press connection	26–29
Combi-set heating / sanitary range	30–33
Dimension of pipe QUADRIGA	30
House entry bend	30
Sealing ring	31
End cap	31
Screw connection	32
Press connection	33
T-branch, heating / sanitary range	34–37
CALPEX-T, -I, -L, type UNO and DUO (∅ 76 – 126 mm)	34
CALPEX-Big-T, -I, -L, type UNO and DUO (∅ 76 – 182 mm)	35–36
CALPEX-T-piece preinsulated	37
Socket, heating range	38
Socket, sanitary range	39
Socket, CALPEX-KMR range	40
Sockets without insulating material	41–42
Accessories	43
Checklist	44
Installation tools, Transport and Storage	45
Trench space dimensions and Laying	46
Aligning the pipe ends and Estimated installation time for CALPEX	47–48
Building entry	49
House connection	50–51
Installation instructions CALPEX	52–55
Stripping, pipe-preparation	52
Screw connection	53
Press connection/Chamber	54
CALPEX-T-Shells	55
Pressure test, Pressure test sheet	56–58
Request per fax	59

Utilise your advantages

CALPEX – the flexible plastic low-temperature system for reliable supply of service water and heat: flexible, energy-efficient, reliable, fast and professional.

CALPEX's new, high-quality, distinctively corrugated outer casing facilitates installation-friendly laying and lastingly protects the high-performance polyurethane composite system. CALPEX reliably and quickly provides access to composite heating systems and is an energy-efficient system to last for decades: an investment in a secure future.



Flexible

Realise small bending radii with low force exertion



Energy-efficient

Reduce energy losses and cut costs

Distinctive corrugation as a trademark

CALPEX - with its corrugated contours and patented outer casing provides a very high degree of flexibility during laying and reliably protects against mechanical influences. CALPEX makes it possible to achieve small bending radii and to guide the pipe around tight curves along the route with low force exertion.

Flexible on the construction site

The improved flexibility of CALPEX allows us to manufacture coils with a reduced internal diameter - so we can supply in even longer lengths. Thus, CALPEX can cope with all route conditions without limitations and with minimal planning expenditure, bringing additional cost savings.

Excellent energy properties

Very low heat losses (λ_{50} 0.0216 W/mK) make CALPEX the frontrunner in terms of energy savings. Thanks to the high-quality, fine-pored, closed-cell, high-pressure foaming, quality is retained for the long term. These outstanding energy properties are confirmed by independent testing institutions. Using CALPEX reduces heating costs and increases energy efficiency in a sustainable manner.





Reliable

Reliability reflected in quality and durability



Fast

Speeding up building and installation work will save time and money

First-class accessories

The non-detachable press fittings for reliable connections and the CALPEX clip shells which can be used without tools for easy, quick and secure installation of supplementary insulation reduce laying expenditure and guarantee a long service life. Instead of laying many short pipe sections, we deliver pipes in the longest possible lengths which reduces the number of underground connections.

Lastingly secure

CALPEX, the top-quality composite system, is longitudinally watertight. If the pipe is damaged by external influences, no cavities (in which water could accumulate and flow towards the building) are formed.

Less excavation work

Thanks to the small outer diameter of the bonded pipe, the CALPEX system can be laid in narrow trenches. The smaller volume minimises the excavation work, speeds up the progress of construction work and thus leads to cost savings.

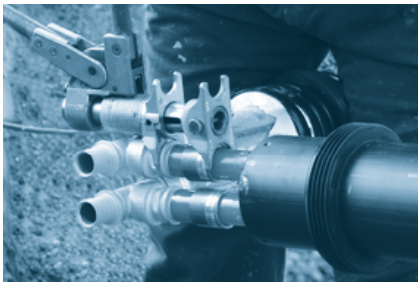

Professional

We listen, innovate and keep our promises

Strong brand

Brugg Pipesystems stands for high quality, innovative products and longstanding experience. We give you individual and goal-oriented advice. The internal quality control system and the observance of all relevant standards ensure that our supplying factories in Germany and Switzerland adhere to the strictest quality standards.

Our development team constantly analyses your future requirements. The obtained findings already get incorporated into today's product solutions, which we optimally adapt to your specific needs. With Brugg Pipesystems, you are on the safe side. One of our strengths is excellent stock availability.



System description

Range of use:

Heating (PN 6) and Sanitary (PN 10)
 Max. temp. for continuous operation: 80 °C
 Max. permitted operating temp.: 95 °C



CALPEX-UNO



CALPEX-DUO



CALPEX-UNO mit HBK
 mit Heizbandkanal (HBK)



CALPEX-QUADRIGA

1. Bonded system

Requirements:
 Fire behaviour:

Factory insulated, flexible pipe systems according EN 15632-1/-2
 Building material class B2 (normally inflammable) according to DIN 4102

2. Carrier pipe

Materials
 Bonding agent
 Oxygen barrier layer
 Requirements

Basic material: High-density polyethylene (PE-HD), peroxide cross-linked (PEXa), colour: natural
 PE-modified, heat-stabilized, colour: red (heating), silver (sanitary)
 Ethylene / vinyl alcohol (EVOH), heat-stabilized, colour: natural
 As per DIN 16892 / DIN 16893 and E DIN EN 12318-2, pipes in series 3.2
 as per DVGW worksheet W 544

Impermeability to oxygen

As per DIN 4729 at 40 °C, oxygen permeability based on the interior pipe volume
 as per DIN 4726 from $\leq 0.10 \text{ g} / (\text{m}^3 \times \text{d})$

Pipe series DIN 16893

Series 5 (SDR 11): for heating (with EVOH barrier)
 Series 3.2 (SDR 7.4): for sanitary (with EVOH barrier)

Long-term behaviour

according to DIN 16892/93

Properties

Unaffected by aggressive water; low pressure losses; very good chemical and
 mechanical resistance

PEXa carrier pipe	Reference temperature °C	Value	Test standard
Density	-	932 - 935 kg/m ³	ISO 1183
Thermal conductivity	-	0.38 W/mK	According to ASTM C 1113
Tensile strength	20	min. 18 N/mm ²	ISO 6259
Tensile strength	80	min. 8 N/mm ²	ISO 6259
Modulus of elasticity	20	600 N/mm ²	ISO 527
Modulus of elasticity	80	200 N/mm ²	ISO 527
Linear expansion coefficient	20	$1.4 \cdot 10^{-4} \text{ 1/K}$	-
Linear expansion coefficient	100	$2.0 \cdot 10^{-4} \text{ 1/K}$	-
Crystallite melting range	-	128 - 134 °C	-
Chem. resistance	20/40/60	-	DIN 8075 B.1

System description

3. Thermal insulation

Materials:

CALPEX heating

CFC-free, cyclopentane-blown polyurethane foam (PUR)

CALPEX sanitary

CFC-free, 100 % CO₂-blown polyurethane foam (PUR)

PUR insulation	Reference temperature °C	CALPEX heating	CALPEX sanitary	Test standard
Density	-	> 50 kg/m ³	> 50 kg/m ³	EN 253
Axial shear strength		≥ 90 kPa		EN 15632-2
Thermal conductivity flexible systems	50	≤ 0.0216 W/mK	≤ 0.0234 W/mK	EN 253 and ISO 8497
Thermal conductivity rigid systems	50	≤ 0.0260 W/mK	-	EN 253 and ISO 8497
Percentage of closed cells	-	≥ 90 %	≥ 90 %	EN 253
Water absorption	100	≤ 10 %	≤ 10 %	EN 15632-1

4. Protective casing

Materials:

linear polyethylene, low density (LLD-PE), seamlessly extruded

Purpose:

mechanical protection and moisture resistance

LLD-PE protective casing	Reference temperature °C	Value	Test standard
Density	-	918 - 922 kg/m ³	ISO 1183
Thermal conductivity	-	0.33 W/mK	DIN 52612
Crystallite melting range	-	122 °C	ISO 11357-3

Pressure loss

Heating, 6 bar
Water temperature 80 °C

1 mmWS = 9.81 Pa

$$\dot{m} \approx \frac{Q \cdot 860}{\Delta T}$$

\dot{m} = Flow rate in kg/h
 Q = Power requirement in kW
 ΔT = Temp. difference, forward and return flow in K

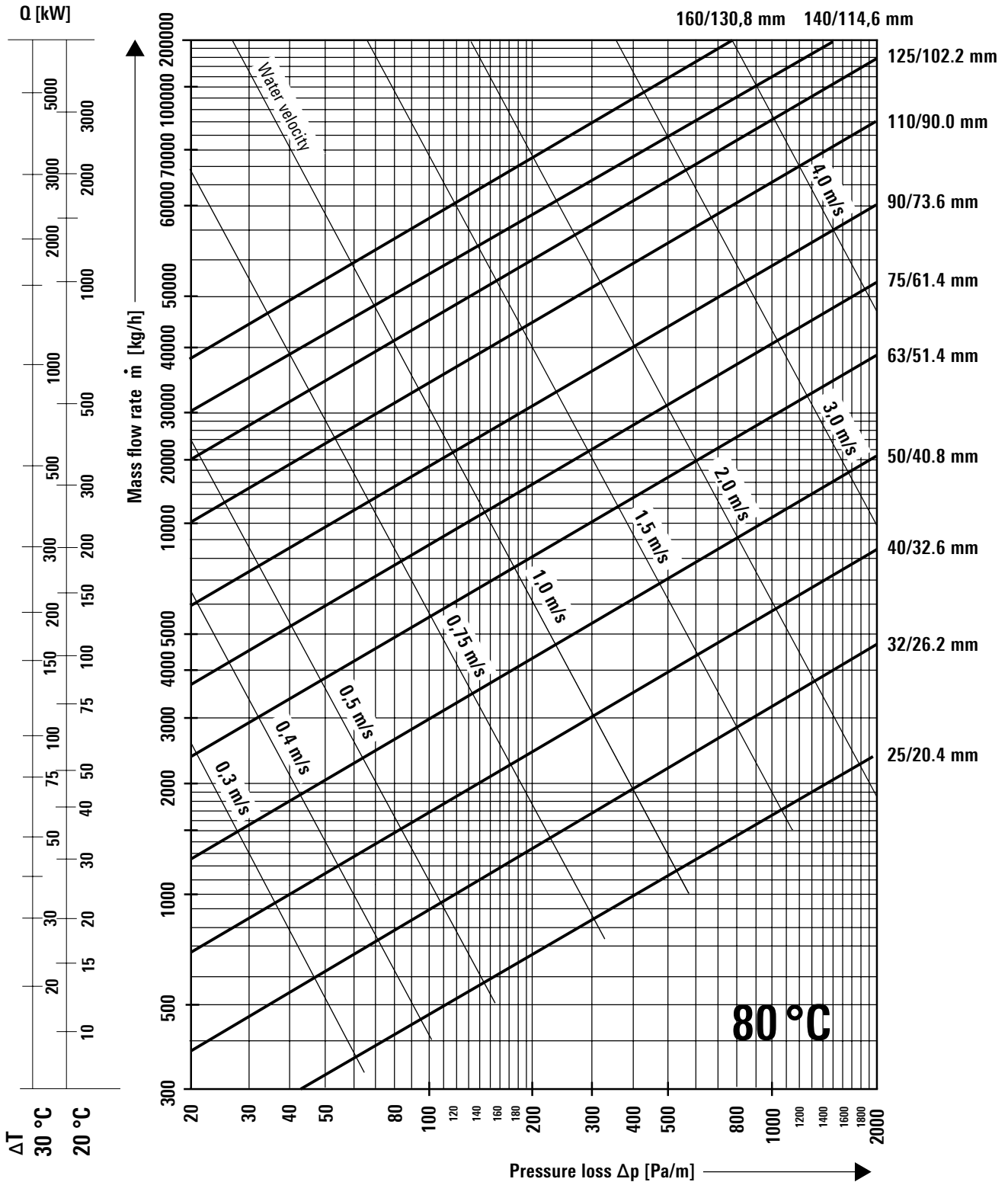

Heat loss

Heating, 6 bar

Heat losses q [W/m] for one UNO pipe						
CALPEX UNO	U-value [W/mK]	Average operating temperature T_B [°C]				
		40°	50°	60°	70°	80°
25/ 76	0.1142	3.43	4.57	5.71	6.85	7.99
25/ 91 PLUS	0.0993	2.98	3.97	4.97	5.96	6.95
32/ 76	0.1442	4.33	5.77	7.21	8.65	10.09
32/ 91 PLUS	0.1212	3.64	4.85	6.06	7.27	8.48
40/ 91	0.1510	4.53	6.04	7.55	9.06	10.57
40/111 PLUS	0.1236	3.71	4.94	6.18	7.42	8.65
50/111	0.1551	4.65	6.20	7.76	9.31	10.86
50/126 PLUS	0.1360	4.08	5.44	6.80	8.16	9.52
63/126	0.1767	5.30	7.07	8.84	10.60	12.37
63/142 PLUS	0.1539	4.62	6.16	7.70	9.23	10.77
75/142	0.1908	5.72	7.63	9.54	11.45	13.36
75/162 PLUS	0.1616	4.85	6.46	8.08	9.70	11.31
90/162	0.2057	6.17	8.23	10.29	12.34	14.40
90/182 PLUS	0.1747	5.24	6.99	8.74	10.48	12.23
110/162	0.2957	8.87	11.83	14.79	17.74	20.70
110/182	0.2355	7.07	9.42	11.78	14.13	16.49
110/202 PLUS	0.1992	5.98	7.97	9.96	11.95	13.94
125/182	0.3026	9.08	12.10	15.13	18.16	21.18
125/202 PLUS	0.2771	8.31	11.08	13.86	16.63	19.40
140/202	0.3084	9.25	12.34	15.42	18.50	21.59
160/250*	0.3028	9.08	12.11	15.14	18.17	21.20

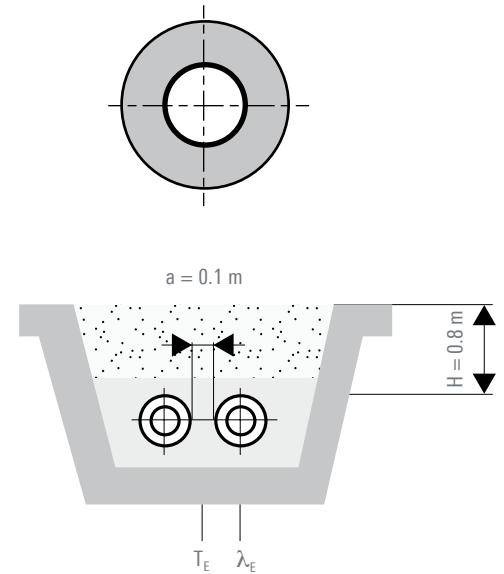

CALPEX DUO (flow and return in one pipe)

Heat losses q [W/m] for one DUO pipe						
CALPEX DUO	U-value [W/mK]	Average operating temperature T_B [°C]				
		40°	50°	60°	70°	80°
25 + 25/ 91	0.1786	5.36	7.14	8.93	10.72	12.50
25 + 25/111 PLUS	0.1392	4.18	5.57	6.96	8.35	9.74
32 + 32/111	0.1829	5.49	7.32	9.15	10.97	12.80
32 + 32/126 PLUS	0.1571	4.71	6.28	7.86	9.43	11.00
40 + 40/126	0.2108	6.32	8.43	10.54	12.65	14.76
40 + 40/142 PLUS	0.1741	5.22	6.96	8.71	10.45	12.19
50 + 50/162	0.1954	5.86	7.82	9.77	11.72	13.68
50 + 50/182 PLUS	0.1662	4.99	6.65	8.31	9.97	11.63
63 + 63/182	0.2381	7.14	9.52	11.91	14.29	16.67
63 + 63/202 PLUS	0.2075	6.23	8.30	10.38	12.45	14.53
75+75/202	0.2802	8.41	11.21	14.01	16.81	19.61

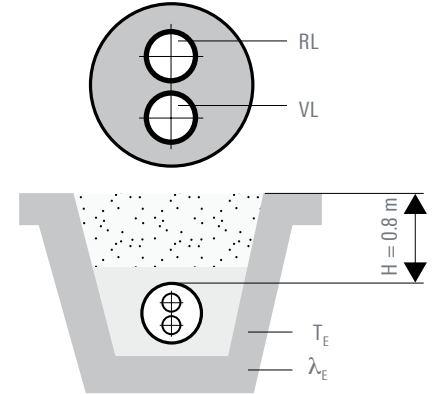

- Type of installation, CPX UNO: 2-pipe, laid in the ground
- Type of installation, CPX DUO: 1-pipe, laid in the ground
- Pipe distance: $a = 0.10$ m
- Cover above pipe: $H = 0.80$ m
- Ground temperature: $T_E = 10$ °C
- Soil conductivity: $\lambda_E = 1.0$ W/mK
- Conductivity of PUR foam: $\lambda_{PU} = 0.0216$ W/mK
- *Conductivity of PUR foam: $\lambda_{PU} = 0.0260$ W/mK
- Conductivity of PEX pipe: $\lambda_{PEXa} = 0.38$ W/mK
- Conductivity of PE pipe: $\lambda_{PE} = 0.33$ W/mK

Note:

Due to the planned revision of standards, the heat losses are not shown as specified within EN 15632.

Heat loss during operation:

- $q = U (T_B - T_E)$ [W/m]
- U = Heat transfer coefficient [W/mK]
- T_B = Average operating temperature [°C]
- T_E = Average ground temperature [°C]
- VL = Flow
- RL = Return

Heat loss

Sanitary, 10 bar

CALPEX UNO

Heat losses q [W/m] for one UNO pipe						
CALPEX UNO	U-value [W/mK]	Average operating temperature T _B [°C]				
		40°	50°	60°	70°	80°
22/ 76	0.1131	3.39	4.52	5.66	6.79	7.92
28/ 76	0.1387	4.16	5.55	6.94	8.32	9.71
32/ 76	0.1588	4.76	6.35	7.94	9.53	11.12
40/ 91	0.1666	5.00	6.66	8.33	10.00	11.66
50/111	0.1713	5.14	6.85	8.57	10.28	11.99
63/126	0.1957	5.87	7.83	9.79	11.74	13.70
32/111 HBK	0.1127	3.38	4.51	5.64	6.76	7.89
40/126 HBK	0.1220	3.66	4.88	6.10	7.32	8.54
50/126 HBK	0.1497	4.49	5.99	7.49	8.98	10.48

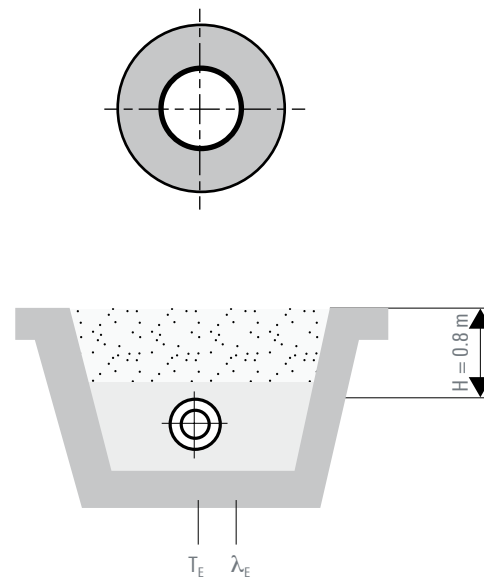

CALPEX DUO

Heat losses q [W/m] for one DUO pipe						
CALPEX DUO	U-value [W/mK]	Average operating temperature T _B [°C]				
		40°	50°	60°	70°	80°
28 + 22/91	0.1956	5.87	7.82	9.78	11.74	13.69
32 + 22/111	0.1677	5.03	6.71	8.39	10.06	11.74
40 + 28/126	0.1878	5.63	7.51	9.39	11.27	13.15
50 + 32/126	0.2476	7.43	9.90	12.38	14.86	17.33

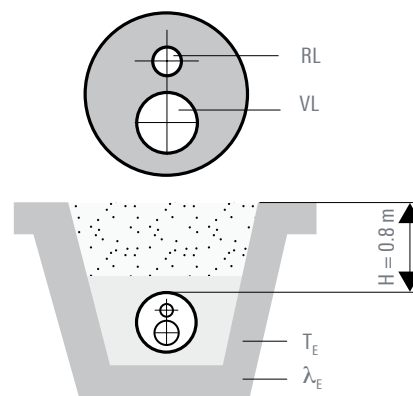

Type of installation, CPX UNO:	1-pipe, laid in the ground
Type of installation, CPX DUO:	1-pipe, laid in the ground
Cover above pipe:	H = 0.80 m
Ground temperature:	T _E = 10 °C
Soil conductivity:	λ _E = 1.0 W/mK
Conductivity of PUR foam:	λ _{PU} = 0.0234 W/mK
Conductivity of PEX pipe:	λ _{PEXa} = 0.38 W/mK
Conductivity of PE pipe:	λ _{PE} = 0.33 W/mK

Heat loss during operation:

$$q = U (T_B - T_E) \text{ [W/m]}$$

U = Heat transfer coefficient [W/mK]

T_B = Average operating temperature [°C]

T_E = Average ground temperature [°C]

Heating range

CALPEX-Heating

Operat. temp.:	max. 95 °C (fluctuating)
Operat. pressure:	6 bar
Carrier pipe:	cross-linked polyethylene PE-Xa with oxygen diffusion barrier (EVOH)
Insulation:	CFC-free, pentane-blown flexible polyurethane hard foam
Protective sheath:	sinusoidal corrugated, seamless extruded polyethylene (LLD-PE)

Single-line pipe CPX-UNO

Dimensions mm	Carrier pipe mm	Nom. diameter**		Bending radius m	Coil length m	Weight kg	Art.-No.
		DN	inches				
25/ 76	25 x 2.3	20	¾	0.45	up to 1000	0.90	1007296
25/ 91 PLUS				0.65	up to 715	1.00	1007238
32/ 76	32 x 2.9	25	1	0.50	up to 1000	1.00	1007297
32/ 91 PLUS				0.70	up to 715	1.38	1007298
40/ 91	40 x 3.7	32	1 ¼	0.55	up to 715	1.39	1007299
40/111 PLUS				0.75	up to 450	1.98	1007300
50/111	50 x 4.6	40	1 ½	0.60	up to 450	1.97	1007301
50/126 PLUS				1.20	up to 291	2.20	1007240
63/126	63 x 5.8	50	2	1.00	up to 291	2.60	1007303
63/142 PLUS				0.85	up to 260	3.49	1007254
75/142	75 x 6.8	65	2 ½	0.70	up to 260	3.39	1007304
75/162 PLUS				0.90	up to 149	4.35	1007316
90/162	90 x 8.2	80	3	1.00	up to 149	4.56	1007305
90/182 PLUS				1.20	up to 86	4.90	1007264
110/162	110 x 10.0	100	4	1.10	up to 149	5.10	1007306
110/182				1.20	up to 86	5.68	1007307
110/202 PLUS*				1.40	up to 80	6.94	1007321
125/182	125 x 11.4	125	5	1.30	up to 86	6.37	1007308
125/202 PLUS*				1.50	up to 80	7.80	1007320
140/202	140 x 12.7	125	5	1.40	up to 80	7.60	1007318
160/250	160 x 14.6	150	6	-	12 (bars)	11.31	1007309



Twin-line pipe CPX-DUO

Dimensions mm	Carrier pipe mm	Nom. diameter**		Bending radius m	Coil length m	Weight kg/m	Art.-No.
		DN	inches				
25 + 25/ 91	2 x 25 x 2.3	20 + 20	2 x ¾	0.55	up to 715	1.34	1007310
25 + 25/111 PLUS				0.75	up to 450	1.91	1007275
32 + 32/111	2 x 32 x 2.9	25 + 25	2 x 1	0.60	up to 450	1.87	1007311
32 + 32/126 PLUS				1.20	up to 291	2.49	1007277
40 + 40/126	2 x 40 x 3.7	32 + 32	2 x 1 ¼	1.00	up to 291	2.48	1007313
40 + 40/142 PLUS				0.85	up to 260	3.28	1007278
50 + 50/162	2 x 50 x 4.6	40 + 40	2 x 1 ½	1.10	up to 149	3.96	1007314
50 + 50/182 PLUS				1.30	up to 86	5.05	1007279
63 + 63/182	2 x 63 x 5.8	50 + 50	2 x 2	1.20	up to 86	5.28	1007315
63 + 63/202 PLUS*				1.40	up to 80	5.90	1007280
75+75/202*	2 x 75 x 5.8	65 + 65	2 x 2 ½	1.40	up to 80	6.84	1007281

* Available on request ** The nominal diameter is based on the size of connection to steel pipe

Coil types and dimensions:

Jumbo coils: 2800 x 800 mm
Maxi coils: 2800 x 1200 mm

Coil supply:

- as section length, as coils and on drums
- delivered coil length may vary (+/- 5%)
- Sea freight coils: on request

House entry bend

CALPEX-House entry bend 90°

Specification UNO:	CPX 25/76 - 125/182:	leg length 1.1 x 1.6 m, medium pipe PE-Xa
	CPX 140/202 - 160/250:	leg length 1.0 x 1.0 m, medium pipe St 37.0 including press fitting and sleeves
Specification DUO:	CPX 25+25/91 - 63+63/182:	leg length 1.1 x 1.6 m, medium pipe PEXa
Insulation:	100% CFC-free, polyurethane hard foam	
Protective sheath:	polyethylene (PE-HD)	

Bend CPX-UNO

Dimensions in mm		Art.-No.
25/ 76	CALPEX-Bend 90° Heating UNO	1000927
25/ 91 PLUS	CALPEX-Bend 90° Heating UNO	1010773
32/ 76	CALPEX-Bend 90° Heating UNO	1010774
32/ 91 PLUS	CALPEX-Bend 90° Heating UNO	1001007
40/ 91	CALPEX-Bend 90° Heating UNO	1010775
40/111 PLUS	CALPEX-Bend 90° Heating UNO	1007383
50/111	CALPEX-Bend 90° Heating UNO	1010776
50/126 PLUS	CALPEX-Bend 90° Heating UNO	1010777
63/126	CALPEX-Bend 90° Heating UNO	1010778
63/142 PLUS	CALPEX-Bend 90° Heating UNO	1010779
75/142	CALPEX-Bend 90° Heating UNO	1010780
75/162 PLUS	CALPEX-Bend 90° Heating UNO	1010781
90/162	CALPEX-Bend 90° Heating UNO	1010782
90/182 PLUS	CALPEX-Bend 90° Heating UNO	1000829
110/162	CALPEX-Bend 90° Heating UNO	1010942
110/182	CALPEX-Bend 90° Heating UNO	1000830
110/202 PLUS	CALPEX-Bend 90° Heating UNO	1008503
125/182	CALPEX-Bend 90° Heating UNO	1010820
125/202 PLUS	CALPEX-Bend 90° Heating UNO	1010935
140/225	CALPEX-Bend 90° Heating UNO	1007066
160/250	CALPEX-Bend 90° Heating UNO	1007012

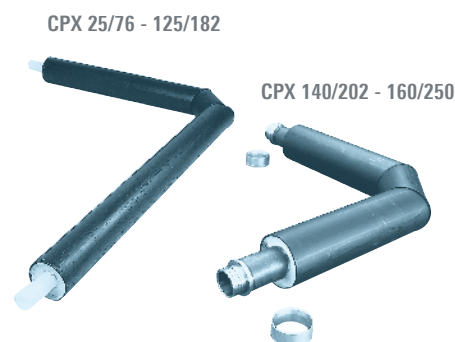

Bend CPX-DUO

Dimensions in mm		Art.-No.
25 + 25/ 91	CALPEX-Bend 90° Heating DUO	1007384
25 + 25/111 PLUS	CALPEX-Bend 90° Heating DUO	1010784
32 + 32/111	CALPEX-Bend 90° Heating DUO	1010785
32 + 32/126 PLUS	CALPEX-Bend 90° Heating DUO	1010786
40 + 40/126	CALPEX-Bend 90° Heating DUO	1010787
40 + 40/142 PLUS	CALPEX-Bend 90° Heating DUO	1010788
50 + 50/162	CALPEX-Bend 90° Heating DUO	1010789
50 + 50/182 PLUS	CALPEX-Bend 90° Heating DUO	1010874
63 + 63/182	CALPEX-Bend 90° Heating DUO	1000831
63 + 63/202	CALPEX-Bend 90° Heating DUO	1010917
75 + 75/202	CALPEX-Bogen 90° Heizung DUO	1057467



Forked pipe

Forked pipe CALPEX

Specification: preinsulated connecting element, length 1800 mm
 Function: connecting between two UNO pipes (Fwd/Return) with a CPX-DUO pipe
 Insulation: CFC-free polyurethane hard foam
 Protective sheath: polyethylene (PE-HD)



Forked pipe CPX-CPX

CALPEX-UNO to CALPEX-DUO, suitable for

UNO-Pipe	DUO-Pipe		Art.-No.
2 x 25/ 76	25 + 25/ 91	PEX medium pipe	1000283
2 x 25/ 91 PLUS	25 + 25/111	PEX medium pipe	1010790
2 x 32/ 76	32 + 32/111	PEX medium pipe	1010791
2 x 32/ 91 PLUS	32 + 32/126	PEX medium pipe	1010834
2 x 40/ 91	40 + 40/126	PEX medium pipe	1010792
2 x 40/111 PLUS	40 + 40/142	PEX medium pipe	1010843
2 x 50/111	50 + 50/162	PEX medium pipe	1010794
2 x 50/126 PLUS	50 + 50/182	PEX medium pipe	1010851
2 x 63/126	63 + 63/182	PEX medium pipe	1000832
2 x 63/142 PLUS	63 + 63/202	PEX medium pipe	1010869
2 x 75/142	75 + 75/202*	Mediumrohre aus PEXa	1062041

* reduction socket \varnothing 225/202 is required



Forked pipe KMR-CPX

Plastic sheath pipe (2x St 37.0) to CALPEX-DUO, suitable for

UNO-Pipe	DUO-Pipe		Art.-No.
2x 26,9/110	26,9 + 26,9/110	PEX medium pipe	1007008
2x 33,7/110	33,7 + 33,7/110	PEX medium pipe	1007009
2x 42,4/125	42,4 + 42,4/125	PEX medium pipe	1007010
2x 48,3/125	48,3 + 48,3/160	PEX medium pipe	1007011
2x 60,3/140	60,3 + 60,3/180	PEX medium pipe	1006760

Sealing ring



Wall sealing ring

comprising a special section neoprene ring, suitable for

Dimensions in mm	Art.-No.	Dimensions in mm	Art.-No.
Outer diameter CALPEX 76	1011597	Outer diameter CALPEX 162	1011602
Outer diameter CALPEX 91	1011598	Outer diameter CALPEX 182	1000835
Outer diameter CALPEX 111	1011599	Outer diameter CALPEX 202	1051309
Outer diameter CALPEX 126	1011600	Outer diameter CALPEX 225	1051310
Outer diameter CALPEX 142	1011601	Outer diameter CALPEX 250	1054850

Wall sealing ring

for carottage and pipe liner (water pressure tight up to < 0.5 bar)

Dimensions in mm	Art.-No.	Dimensions in mm	Art.-No.
Outer diameter CALPEX 76	1011067	Outer diameter CALPEX 162	1011073
Outer diameter CALPEX 91	1011069	Outer diameter CALPEX 182	1009339
Outer diameter CALPEX 111	1011070	Outer diameter CALPEX 202	1011074
Outer diameter CALPEX 126	1011071	Outer diameter CALPEX 225	1009340
Outer diameter CALPEX 142	1009338	Outer diameter CALPEX 250	1011075
		Aquagard-Set (Primer)	1010680

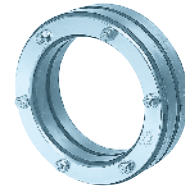

For centering we recommend a supplementary sealing ring

Diameter of core holes and pipe liners on page 49

End cap

End cap CPX for dry areas

as termination for house connections, comprising PE-LD

End cap for CALPEX-UNO, suitable for

Dimensions in mm	Art.-No.
25/ 76	1011701
25/ 91 PLUS	1011702
32/ 76	1011708
32/ 91 PLUS	1000822
40/ 91	1011709
40/111 PLUS	1011710
50/111	1011710
50/126 PLUS	1011705
63/126	1011711
63/142 PLUS	1011706
75/142	1011712
75/162 PLUS	1011707
90/162	1011713
90/182 PLUS	1000836
110/162	1011714
110/182	1000837
110/202 PLUS	1012242
125/182	1011699
125/202 PLUS	1012243
140/202	1011697
160/250	not available

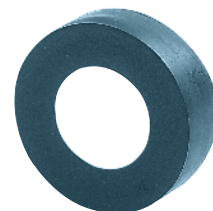

End cap for CALPEX-DUO, suitable for



Dimensions in mm	Art.-No.
25 + 25/ 91	1011721
25 + 25/111 PLUS	1011715
32 + 32/111	1011718
32 + 32/126 PLUS	1011716
40 + 40/126	1011719
40 + 40/142 PLUS	1011717
50 + 50/162	1011720
50 + 50/182 PLUS	1012244
63 + 63/182	1000838
63 + 63/202 PLUS	1012245
75 + 75/202	1059112

Shrinking end cap CPX for humid areas

Heat shrinking, as termination for house connections, comprising polymerised and modified polyolefin, coated with sealing adhesive resistant to temperatures up to 125 °C. Including temperature measuring tapes and grinding belt.

Shrinking end cap for CALPEX-UNO, suitable for

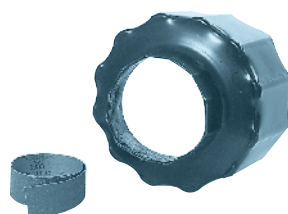

Dimensions in mm	Art.-No.
25/ 76	1010754
25/ 91 PLUS	1010715
32/ 76	1010715
32/ 91 PLUS	1010715
40/ 91	1013507
40/111 PLUS	1013507
50/111	1013508
50/126 PLUS	1013508
63/126	1013508
63/142 PLUS	1013508
75/142	1013508
75/162 PLUS	1010714
90/162	1010714
90/182 PLUS	1010714
110/162	1010896
110/182	1010896
110/202 PLUS	1010896
125/182	1010896
125/202 PLUS	1010896
140/202	1008724
140/225	1010896
160/250	1010905

Shrinking end cap for CALPEX-DUO, suitable for



Dimensions in mm	Art.-No.
25 + 25/ 91	1010755
25 + 25/111 PLUS	1010679
32 + 32/111	1010679
32 + 32/126 PLUS	1010679
40 + 40/126	1010679
40 + 40/142 PLUS	1010679
50 + 50/162	1010939
50 + 50/182 PLUS	1010939
63 + 63/182	1000509
63 + 63/202 PLUS	1000509
75+ 75/202	not available

Screw connection, heating range

Connection piece CPX with external thread

screw connection made of brass, suitable for

PEX-Pipe in mm	External thread in inches	Art.-No.
25 x 2,3	3/4	1010584
32 x 2,9	1	1010586
40 x 3,7	1 1/4	1010587
50 x 4,6	1 1/2	1010588
63 x 5,7	2	1010589
75 x 6,8	2 1/2	1010590
90 x 8,2	3	1010591
110 x 10,0	4	1010881



ø 25-63 mm



ø 75-110 mm

Connection piece CPX with weld-on end

screw connection made of St 37.0, suitable for

PEX-Pipe in mm	Weld-on end in mm	Art.-No.
25 x 2,3	26,9 x 2,65	1010597
32 x 2,9	33,7 x 2,3	1010599
40 x 3,7	42,4 x 2,6	1010600
50 x 4,6	48,3 x 2,6	1010601
63 x 5,7	60,3 x 2,9	1010602
75 x 6,8	76,1 x 3,2	1010603
90 x 8,2	88,9 x 3,2	1010604
110 x 10,0	114,3 x 3,6	1010882
125 x 11,4	139,7 x 3,6	on request
140 x 12,7	139,7 x 3,6	1010038



ø 25-63 mm



ø 75-110 mm



ø 125-140 mm

Coupling piece CPX, equal

screw connection made of brass, suitable for

PEX-Pipe in mm	on PEX-Pipe in mm	Art.-No.
25 x 2,3	25 x 2,3	1010607
32 x 2,9	32 x 2,9	1010609
40 x 3,7	40 x 3,7	1010611
50 x 4,6	50 x 4,6	1010613
63 x 5,7	63 x 5,7	1010615
75 x 6,8	75 x 6,8	1010616
90 x 8,2	90 x 8,2	1010618
110 x 10,0	110 x 10,0	1010884

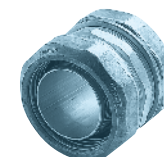

ø 25-63 mm

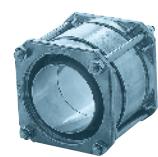

ø 75-110 mm

For sockets in the earth we recommend press connections

Coupling piece CPX, reduced

screw connection made of brass, suitable for



ø 25-63 mm



ø 75-110 mm

PEX-Pipe in mm	on PEX-Pipe in mm	Art.-No.
32 x 2,9	25 x 2,3	1010610
40 x 3,7	32 x 2,9	1010612
50 x 4,6	40 x 3,7	1010614
63 x 5,8	50 x 4,6	on request
75 x 6,8	63 x 5,8	on request
90 x 8,2	75 x 6,8	on request
110 x 10,0	90 x 8,2	on request

T-Piece CPX with up to multi-stage reductions

screw connection made of brass, suitable for



Dimension d1-d2-d3	Art.-No.
25-25-25	1010631
32-32-32	1010632
32-25-32	1010633
32-25-25	1010634
40-40-40	1010635
40-32-40	1010636
40-25-40	1010637
40-32-32	1010638
40-25-32	on request
50-50-50	1010639
50-40-50	1010640
50-32-50	1010641
50-25-50	1010642
50-40-40	1010643
50-32-40	1010644
50-25-40	1010645
63-63-63	1010646
63-50-63	1010647
63-40-63	1010648
63-32-63	1010649
63-25-63	1010650
63-50-50	1010651
63-40-50	1010652
63-32-50	on request
63-25-50	on request

For sockets in the earth we recommend press connections

Dimensions	
d1-d2-d3	Art.-No.
75-75-75	1010654
75-63-75	1010655
75-50-75	1010656
75-40-75	1010657
75-32-75	1010658
75-25-75	1010659
75-63-63	1010660
75-50-63	1010661
75-40-63	on request
75-32-63	on request
75-25-63	on request
90-90-90	on request
90-75-90	on request
90-63-90	1010662
90-50-90	1010663
90-40-90	on request
90-32-90	on request
90-25-90	on request
90-75-75	on request
90-63-75	on request
90-50-75	on request
90-40-75	on request
90-32-75	on request
90-25-75	on request
110-110-110	1010955
110-90-110	1010956
110-75-110	on request
110-63-110	1010957
110-50-110	on request
110-40-110	on request
110-32-110	1010958
110-25-110	1010959
110-90-90	1010960
110-75-90	on request
110-63-90	on request
110-50-90	on request
110-40-90	on request
110-32-90	on request
110-25-90	on request

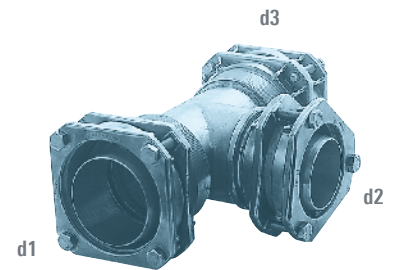

For sockets in the earth we recommend press connections

Press connection, heating range



Connection piece CPX with external thread

press connection made of brass, suitable for

PEX-Pipe in mm	Male thread in inches	Art.-No.
25 x 2,3	3/4	1011518
32 x 2,9	1	1011519
40 x 3,7	1 1/4	1011520
50 x 4,6	1 1/2	1011521
63 x 5,8	2	1011522
75 x 6,8	2 1/2	1011523
90 x 8,2	3	1011524
110 x 10,0	4	1011525
125 x 11,4	5	1011503
160 x 14,6	6	1011514



Connection piece CPX with weld-on end

press connection made of St 37.0, suitable for

PEX-Pipe in mm	Weld-on end in mm	Art.-No.
25 x 2,3	26,9 x 2,65	1011534
32 x 2,9	33,7 x 2,3	1011536
40 x 3,7	42,4 x 2,6	1011538
50 x 4,6	48,3 x 2,6	1011540
63 x 5,8	60,3 x 2,9	1011542
75 x 6,8	76,1 x 3,2	1011544
90 x 8,2	88,9 x 3,2	1011546
110 x 10,0	114,3 x 3,6	1011548
125 x 11,4	139,7 x 3,6	1011515
140 x 12,7	139,7 x 3,6	1011468
160 x 14,6	168,3 x 4,1	1011516



Coupling piece CPX, equal

press connection made of brass, suitable for

PEX-Pipe in mm	on PEX-Pipe in mm	Art.-No.
25 x 2,3	25 x 2,3	1011549
32 x 2,9	32 x 2,9	1011550
40 x 3,7	40 x 3,7	1011552
50 x 4,6	50 x 4,6	1011554
63 x 5,8	63 x 5,8	1011556
75 x 6,8	75 x 6,8	1011558
90 x 8,2	90 x 8,2	1011560
110 x 10,0	110 x 10,0	1011562
125 x 11,4	125 x 11,4	1011504
140 x 12,7	140 x 12,7	1011465
160 x 14,6	160 x 14,6	1011506

Required press tool kit on page 43

CPX-T, CPX-L and CPX-I for preinsulating on page 34

Coupling piece CPX, reduced

press connection made of brass, suitable for

PEX-Pipe in mm	on PEX-Pipe in mm	Art.-No.
32 x 2.9	25 x 2.3	1011508
40 x 3.7	32 x 2.9	1011509
50 x 4.6	40 x 3.7	1011510
63 x 5.7	50 x 4.6	1000293
75 x 6.8	63 x 5.7	1011511
90 x 8.2	75 x 6.8	1011512
110 x 10.0	90 x 8.2	1011513
125 x 11.4	110 x 10.0	1011505**
140 x 12.7	125 x 11.4	1011466**
160 x 14.6	125 x 11.4	1011507**

** steel

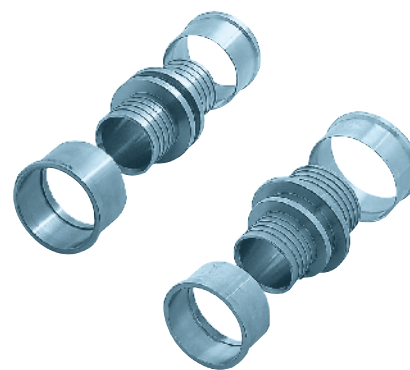

T-Piece CPX with up to multi-stage reductions

press connection made of different materials, suitable for

Dimensions	Brass	Steel (St 37.0)
d1-d2-d3	Art.-No.	Art.-No.
25-25-25	1011412	1011320
32-32-32	1001012	1011321
32-25-32	1011414	1011323
32-25-25	1011413	1011325
40-40-40	1011418	1011326
40-32-40	1011417	1011327
40-25-40	1011416	1011328
40-32-32	1000975*	1011330
40-25-32	1011415*	1011332
50-50-50	1007232	1011334
50-40-50	1000270	1011335
50-32-50	1000973	1011336
50-25-50	1011420	1011337
50-40-40	1011421*	1011339
50-32-40	1000974	1011340
50-25-40	1011419	1011341
63-63-63	1007233	1011343
63-50-63	1011424	1011344
63-40-63	1007234	1011345
63-32-63	1000395	1011346
63-25-63	1011422	1011347
63-50-50	1000394	1011349
63-40-50	1011423	1011350
63-32-50	1000251	1011351
63-25-50	-	1011353
75-75-75	1011432	1011355
75-63-75	1011431	1011356
75-50-75	1011429	1011357
75-40-75	1011428	1011358
75-32-75	1011427	1011359
75-25-75	1011425	1011360
75-63-63	1011430	1011361
75-50-63	1000295	1011362

* soldered

Other T-pieces made of steel/stainless steel on request

Required press tool kit on page 43

CPX-T, CPX-L and CPX-I for preinsulating on page 34

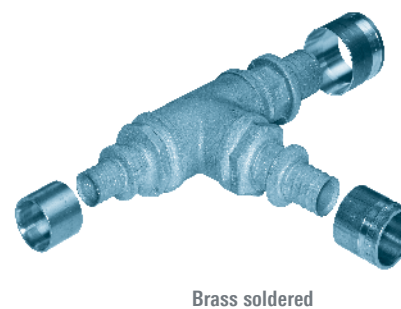
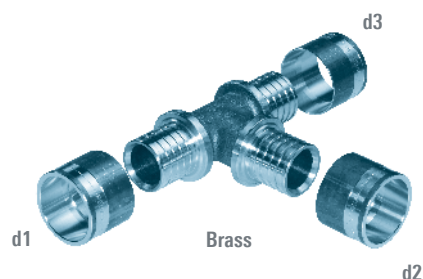



Dimensions d1-d2-d3	Brass Art.-No.	Steel (St 37.0) Art.-No.	
75-40-63	-	1011363	
75-32-63	68388	1011364	
75-25-63	-	1011366	
90-90-90	68408	1011368	
90-75-90	-	1011369	
90-63-90	68405	1011370	
90-50-90	-	1011371	
90-40-90	68401	1011372	
90-32-90	68399	1011373	
90-25-90	-	1011375	
90-75-75	-	1011377	
90-63-75	-	1011378	
90-50-75	-	1011379	
90-40-75	-	1011380	
90-32-75	-	1011381	
90-25-75	-	1011383	
110-110-110	68422	1011385	
110-90-110	-	1011386	
110-75-110	-	1011387	
110-63-110	68417	1011388	
110-50-110	10733	1011389	
110-40-110	-	1011390	
110-32-110	68412	1011391	
110-25-110	-	1011393	
110-90-90	-	1011395	
110-75-90	-	1011396	
110-63-90	-	1011397	
110-50-90	-	1011398	
110-40-90	-	1011399	
110-32-90	-	1011400	
110-25-90	-	1011402	
125-125-125	-	1008669	-
125-110-125	-	1008671	-
125-90-125	-	1011457	-
125-75-125	-	1011455	-
125-63-125	-	1011453	-
125-50-125	-	1011451	-
125-40-125	-	1011449	-
125-32-125	-	1011447	-
125-25-125	-	1011445	-
125-125-110	-	1008670	-
125-110-110	-	1011458	-
125-90-110	-	1011456	-
125-75-110	-	1011454	-
125-63-110	-	1011452	-
125-50-110	-	1011450	-
125-40-110	-	1011448	-
125-32-110	-	1011446	-
125-25-110	-	1011444	-

Other T-pieces made of steel/stainless steel on request

Required press tool kit on page 43

T-Shell, I-Shell and L-Shell for preinsulating on page 34

Elbow 90° CPX, equal

of brass for connecting two CALPEX-district heating pipes, suitable for

PEX-Pipe in mm	on PEX-Pipe in mm	Art.-No.
25 x 2,3	25 x 2,3	1000779
32 x 2,9	32 x 2,9	1000780
40 x 3,7	40 x 3,7	1004928
50 x 4,6	50 x 4,6	1004924
63 x 5,8	63 x 5,8	1007624
75 x 6,8	75 x 6,8	1007625
90 x 8,2	90 x 8,2	1000781
110 x 10,0	110 x 10,0	1007180
125 x 11,4	125 x 11,4	1008258*

* steel

Required press tool kit on page 41



Electrofusion fitting

Coupling piece CPX, equal, electrofusion fitting

for connecting two CALPEX-district heating pipes, suitable for

PEX-Pipe in mm	on PEX-Pipe in mm	Art.-No.
50 x 4,6	50 x 4,6	1010314
63 x 5,8	63 x 5,8	1009835
75 x 6,8	75 x 6,8	1009311
90 x 8,2	90 x 8,2	1009312
110 x 10,0	110 x 10,0	1009313
125 x 11,4	125 x 11,4	1009314
160 x 14,6	160 x 14,6	1009315



Elbow 90° CPX, equal, electrofusion fitting

for connecting two CALPEX-district heating pipes, suitable for

PEX-Pipe in mm	on PEX-Pipe in mm	Art.-No.
75 x 6,8	75 x 6,8	1009451
90 x 8,2	90 x 8,2	1009452
110 x 10,0	110 x 10,0	1009453
125 x 11,4	125 x 11,4	1009454



T-piece equal

PEX-Pipe in mm	Art.-No.
50 x 4,6	1010291
63 x 5,8	1010310
75 x 6,8	1010309
90 x 8,2	1010308
110 x 10,0	1009816
125 x 11,4	1010052



Flange connection

PEX-Pipe in mm	Art.-No.
75 x 6,8	1012320
90 x 8,2	1012319
110 x 10,0	1012317
125 x 11,4	1012318

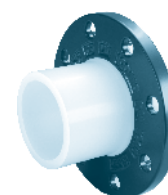

Leasable tool kits for electrofusion fitting for PEXa pipes

comprising welding tool and clamps

Article	Art.-No.
Tool set without pipe cutter	1013777
Additional pipe clamps	1013778
Pipe cutter 50-125 mm	1011605
Pipe cutter 110-160 mm	1011308



T-Shell, I-Shell and L-Shell for preinsulating on page 34

The electrofusion fittings are installed exclusively by certified fitters and special welding tools

Sanitary range

CALPEX-Sanitary

Operat. temp.:	max. 95 °C (fluctuating)
Operat. pressure:	10 bar
Carrier pipe:	cross-linked polyethylene PE-Xa with oxygen diffusion barrier (EVOH)
Insulation:	CFC-free, CO ₂ -blown flexible polyurethane hard foam
Outer sheath:	sinusoidal corrugated, seamless extruded polyethylene (LLD-PE)

Single-line pipe CPX-UNO



Dimensions mm	Carrier pipe mm	Nom. diameter*		Bending radius m	Coil length m	Weight kg	Art.-No.
		DN	inches				
22/ 76	22 x 3,0	16	5/8	0,45	up to 1000	0,96	1010709
28/ 76	28 x 4,0	20	3/4	0,50	up to 1000	1,06	1010711
32/ 76	32 x 4,4	25	1	0,50	up to 1000	1,12	1010690
40/ 91	40 x 5,5	32	1 1/4	0,55	up to 715	1,56	1010692
50/111	50 x 6,9	40	1 1/2	0,60	up to 450	2,25	1010694
63/126	63 x 8,7	50	2	1,00	up to 291	3,06	1010697

Twin-line pipe CPX-DUO



Dimensions mm	Carrier pipe mm	Nom. diameter*		Bending radius m	Coil length m	Weight kg	Art.-No.
		DN	inches				
28 + 22/ 91	28 x 4,0 + 22 x 3,0	20 + 16	3/4 + 5/8	0,55	up to 715	1,47	1010698
32 + 22/111	32 x 4,4 + 22 x 3,0	25 + 16	1 + 5/8	0,60	up to 450	1,95	1010700
40 + 28/126	40 x 5,5 + 28 x 4,0	32 + 20	1 1/4 + 3/4	1,00	up to 291	2,60	1010703
50 + 32/126	50 x 6,9 + 32 x 4,4	40 + 25	1 1/2 + 1	1,00	up to 291	2,96	1010706

CALPEX-Sanitary, with heating tape

Operat. temp.:	max. 95 °C (fluctuating)
Operat. pressure:	10 bar
Carrier pipe:	cross-linked polyethylene PE-Xa with oxygen diffusion barrier (EVOH)
Heating channel:	for frost protection and heating tape for hot water heat tracing (inner width: 18 x 8 mm)
Insulation:	CFC-free CO ₂ -blown flexible polyurethane hard foam
Outer sheath:	sinusoidal corrugated, seamless extruded polyethylene (LLD-PE)

Single-line pipe CPX-UNO-HCC with heating tape



Dimensions mm	Carrier pipe mm	Nom. diameter*		Bending radius m	Coil length m	Weight kg	Art.-No.
		DN	inches				
32/111	32 x 4,4	25	1	0,60	up to 450	1,83	1011317
40/126	40 x 5,5	32	1 1/4	1,00	up to 291	2,49	1011695
50/126	50 x 6,9	40	1 1/2	1,00	up to 291	2,76	1011315

* The nominal diameter is based on the size of connection to steel pipe

Coil types and dimensions:

Jumbo coils:	2800 x 800 mm
Maxi coils:	2800 x 1200 mm

Coil supply:

- as section length, as coils and on drums
- delivered coil length may vary (+/- 5%)
- Sea freight coils: on request

House entry bend

CALPEX-House entry bend 90°

Specification:	leg length 1,1 x 1,6 m
Carrier pipe:	cross-linked polyethylene (PE-Xa)
Insulation:	100% CFC-free polyurethane hard foam
Protective sheath:	polyethylene (PE-HD)

Bend CPX-UNO

Dimensions in mm	DN	inches		Art.-No.
22/ 76	16	$\frac{5}{8}$	CALPEX-Bend 90° Sanitary UNO	1013788
28/ 76	20	$\frac{3}{4}$	CALPEX-Bend 90° Sanitary UNO	1013789
32/ 76	25	1	CALPEX-Bend 90° Sanitary UNO	1013794
40/ 91	32	$1\frac{1}{4}$	CALPEX-Bend 90° Sanitary UNO	1013795
50/111	40	$1\frac{1}{2}$	CALPEX-Bend 90° Sanitary UNO	1013796
63/126	50	2	CALPEX-Bend 90° Sanitary UNO	1013797



Bend CPX-DUO

Dimensions in mm	DN	inches		Art.-No.
28 + 22/ 91	20 + 16	$\frac{3}{4} + \frac{5}{8}$	CALPEX-Bend 90° Sanitary DUO	1013790
32 + 22/111	25 + 16	$1 + \frac{5}{8}$	CALPEX-Bend 90° Sanitary DUO	1013791
40 + 28/126	32 + 20	$1\frac{1}{4} + \frac{3}{4}$	CALPEX-Bend 90° Sanitary DUO	1013792
50 + 32/126	40 + 25	$1\frac{1}{2} + 1$	CALPEX-Bend 90° Sanitary DUO	1013793



Sealing ring

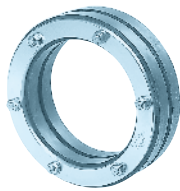

Wall sealing ring

comprising a special section neoprene ring, suitable for

Dimensions in mm	Art.-No.	Dimensions in mm	Art.-No.
Outer diameter CALPEX 76	1011597	Outer diameter CALPEX 111	1011599
Outer diameter CALPEX 91	1011598	Outer diameter CALPEX 126	1011600

Wall sealing ring

for carottage and pipe liner (water pressure tight up to < 0.5 bar)

Dimensions in mm	Art.-No.	Dimensions in mm	Art.-No.
Outer diameter CALPEX 76	67127	Outer diameter CALPEX 111	1010070
Outer diameter CALPEX 91	67129	Outer diameter CALPEX 126	1011071
Aquagard-Set (Primer)	59627		

For centering we recommend a supplementary sealing ring

Diameter of core holes and pipe liners on page 49

End cap

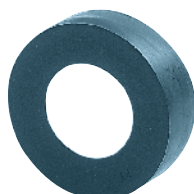
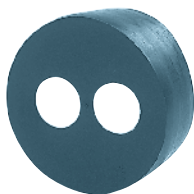
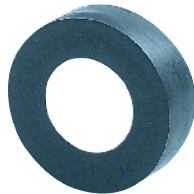

End cap CPX for dry areas

as termination for house connections, suitable for: PE-LD

End cap for CALPEX-UNO, suitable for

Dimensions in mm	DN	inches	Art.-No.
22/ 76	16	5/8	1011700
28/ 76	20	3/4	1011701
32/ 76	25	1	1011708
40/ 91	32	1 1/4	1011709
50/111	40	1 1/2	1011710
63/126	50	2	1011711

End cap CALPEX-DUO, suitable for

Dimensions in mm	DN	inches	Art.-No.
28 + 22/ 91	20 + 16	3/4 + 5/8	1011723
32 + 22/111	25 + 16	1 + 5/8	1011724
40 + 28/126	32 + 20	1 1/4 + 3/4	1011725
50 + 32/126	40 + 25	1 1/2 + 1	1011726

End cap for CALPEX-UNO with heating tape channel, suitable for

Dimensions in mm	DN	inches	Art.-No.
32/111	25	1	1011703
40/126	32	1 1/4	1011704
50/126	40	1 1/2	1011705

Heat shrinkable end cap CPX for humid areas

Heat shrinking, as termination for house connections, comprising polymerised and modified polyolefin, coated with sealing adhesive resistant to temperatures up to 125 °C. Including temperature measuring tapes and grinding belt.

Heat shrinkable end cap for CALPEX-UNO, suitable for

Dimensions in mm	DN	inches	Art.-No.
22/ 76	16	$\frac{5}{8}$	1010754
28/ 76	20	$\frac{3}{4}$	1010715
32/ 76	25	1	1010715
40/ 91	32	1 $\frac{1}{4}$	1013507
50/111	40	1 $\frac{1}{2}$	1013508
63/126	50	2	1013508

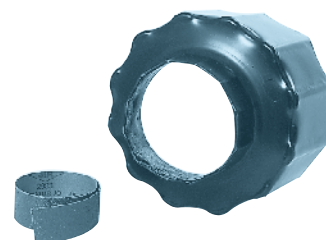

Heat shrinkable end cap for CALPEX-DUO, suitable for

Dimensions in mm	DN	inches	Art.-No.
28 + 22/ 91	20 + 16	$\frac{3}{4} + \frac{5}{8}$	1010755
32 + 22/111	25 + 16	1 + $\frac{5}{8}$	1010679
40 + 28/126	32 + 20	1 $\frac{1}{4}$ + $\frac{3}{4}$	1010679
50 + 32/126	40 + 25	1 $\frac{1}{2}$ + 1	1010679

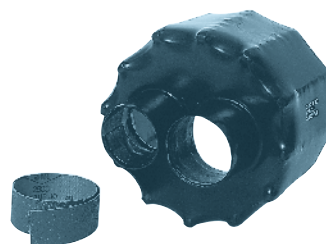

Shrinkable end cap for CALPEX-UNO with heating band channel, suitable for

Dimensions in mm	DN	inches	Art.-No.
32/111	25	1	1013507
40/126	32	1 $\frac{1}{4}$	1013507
50/126	40	1 $\frac{1}{2}$	1013508

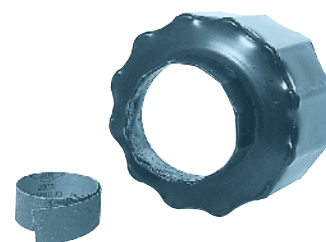

Screw connection, sanitary range

Connection piece CPX with external thread

screw connection made of brass, suitable for

PEX-Pipe in mm	External thread in inches	Art.-No.
22 x 3.0	$\frac{3}{4}$	1010583
28 x 4.0	$\frac{3}{4}$	1010585
32 x 4.4	1	1010592
40 x 5.5	1 $\frac{1}{4}$	1010593
50 x 6.9	1 $\frac{1}{2}$	1010594
63 x 8.7	2	1010595





Connection piece CPX with weld-on end
screw connection made of St 37.0, suitable for

PEX-Pipe in mm	Weld-on end in mm	Art.-No.
22 x 3.0	26.9 x 2.65	1010596

Weld-on ends must only be used in the range of heating



Coupling CPX, equal, screw connection piece
of brass for connecting two CALPEX-district heating pipes, suitable for

PEX-Pipe in mm	on PEX-Pipe in mm	Art.-No.
22 x 3.0	22 x 3.0	1010606
28 x 4.0	28 x 4.0	1010608
32 x 4.4	32 x 4.4	1010619
40 x 5.5	40 x 5.5	1010621
50 x 6.9	50 x 6.9	1010623
63 x 8.7	63 x 8.7	1010625



Coupling CPX, reduced, screw connection piece
of brass for connecting two CALPEX-district heating pipes, suitable for

PEX-Pipe in mm	on PEX-Pipe in mm	Art.-No.
28 x 4.0	22 x 3.0	1008594

For sockets in the earth, we recommend press connections

Press connection, sanitary range



Connection piece CPX with external thread
press connection made of brass, suitable for

PEX-Pipe in mm	External thread in inches	Art.-No.
22 x 3.0	3/4	1011526
28 x 4.0	3/4	1011527
32 x 4.4	1	1011528
40 x 5.5	1 1/4	1011529
50 x 6.9	1 1/2	1011530
63 x 8.7	2	1011531

Connection piece CPX with weld-on end

press connection made of St 37.0, suitable for

PEX-Pipe in mm	Weld-on end in mm	Art.-No.
22 x 3.0	26.9 x 2.65	10115325
28 x 4.0	26.9 x 2.65	10111533



Weld-on ends are to be used in heating range only

Coupling CPX, equal, press connection

of brass for connecting two CALPEX-district heating pipes, suitable for

PEX-Pipe in mm	on PEX-Pipe in mm	Art.-No.
22 x 3.0	22 x 3.0	1008403
28 x 4.0	28 x 4.0	1011564
32 x 4.4	32 x 4.4	1011566
40 x 5.5	40 x 5.5	1011568
50 x 6.9	50 x 6.9	1011570
63 x 8.7	63 x 8.7	1011572



Coupling CPX, reduced, press connection

of brass for connecting two CALPEX-district heating pipes, suitable for

PEX-Pipe in mm	on PEX-Pipe in mm	Art.-No.
28 x 4.0	22 x 3.0	1011565
32 x 4.4	28 x 4.0	1011567
40 x 5.5	32 x 4.4	1011569
50 x 6.9	40 x 5.5	1011571
63 x 8.7	50 x 6.9	1011573



T-Piece CPX

of brass for connecting three CALPEX-sanitary pipes, suitable for

Dimension d1-d2-d3	Art.-No.
22-22-22	1000609
22-28-22	1001013
28-32-28	1012039
28-28-28	1000607
28-22-28	1012035
28-22-22	1000699
28-40-28	1007263
32-40-32	1000774
32-32-32	1000658
32-28-32	1000611
32-22-32	1000703
32-32-28	1000979
32-28-28	1000610
32-22-28	1000700
32-32-22	1000928
32-28-22	1007246
32-22-22	1001015

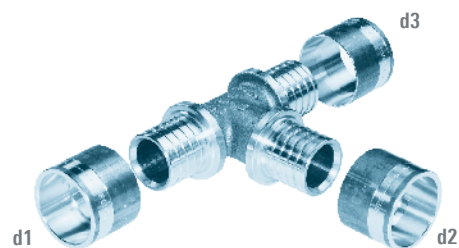

Required press tool kit on page 43

T-Shell, I-Shell and L-Shell for preinsulating on page 34

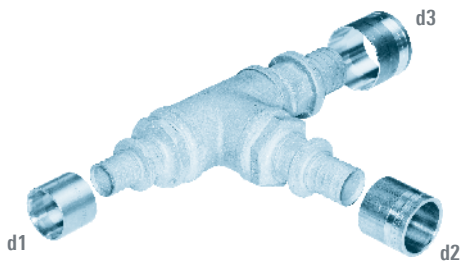

Dimension d1-d2-d3	Art.-Nr.
40-50-40	1012040
40-40-40	1000662
40-32-40	1012036
40-28-40	1000697
40-22-40	1000645
40-40-32	1012038
40-32-32	1000722
40-28-32	1000707
40-22-32	1000698
40-50-28	1007251
40-40-28	1000993
40-22-28	1000704
50-50-50	1000720
50-40-50	1000721
50-32-50	1000644
50-28-50	1000723
50-22-32	1000408
50-22-50	1000783
50-50-40	1000828
50-40-40	1000708
50-32-32	1000294
50-32-40	1000702
50-28-40	1000709
50-22-40	1000710
50-50-32	1000701
50-40-32	1000705
50-28-32	1007241
50-50-28	1007250
50-40-28	1007260
50-28-28	1007261
63-63-63	1000711
63-50-63	1000712
63-40-63	1000713
63-32-63	1000714
63-28-40	1000262
63-28-63	1000715
63-22-63	1000716
63-50-50	1000717
63-40-40	1000363
63-40-50	1000718
63-32-50	1012276
63-28-50	1000719
63-63-40	1000696
63-50-40	1000706

Required press tool kit on page 43

T-Shell, I-Shell and L-Shell for preinsulating on page 34

Elbow 90° CPX, equal

of brass for connecting two CALPEX-sanitary pipes, suitable for

PEX-Pipe in mm	on PEX-Pipe in mm	Art.-No.
22 x 3,0	22 x 3,0	1007626
28 x 4,0	28 x 4,0	1006705
32 x 4,4	32 x 4,4	1004939
40 x 5,5	40 x 5,5	1000787
50 x 6,9	50 x 6,9	1000788
63 x 8,6	63 x 8,6	1000789



Required press tool kit on page 43

T-Shell, I-Shell and L-Shell for preinsulating on page 34

CALPEX - easy to connect



Combi-set heating / sanitary range

CALPEX-Heating and Sanitary

Operat. temp.:	max. 95 °C (fluctuating)
Operat. pressure:	heating 6 bar / sanitary 10 bar
Carrier pipe:	cross-linked polyethylene (PE-Xa) with oxygen diffusion barrier
Insulation:	CO ₂ -blown flexible polyurethane hard foam
Protective sheath:	sinusoidal corrugated, seamless extruded polyethylene (LLD-PE)



Quadro pipeline CPX-QUADRIGA

Dimensions mm	Carrier pipe mm	Nom. diameter*		Coil length m	Weight kg/m	Art.-No.
		DN	inches			
H = 2 x 25, S = 28 + 22, A = 142		H = 2 x 20, S = 20 + 16	H = ¾ + ¾, S = ¾ + ⅝	up to 180	3,25	1011971
H = 2 x 32, S = 28 + 22, A = 142		H = 2 x 25, S = 20 + 16	H = 1 + 1, S = ¾ + ⅝	up to 180	3,39	1011950
H = 2 x 32, S = 32 + 22, A = 142		H = 2 x 25, S = 25 + 16	H = 1 + 1, S = 1 + ⅝	up to 180	3,41	1011973
H = 2 x 40, S = 40 + 28, A = 162		H = 2 x 32, S = 32 + 20	H = 1 ¼ + 1 ¼, S = 1 ¼ + ¾	up to 105	4,15	1011975

* The nominal diameter is based on the size of connection to steel pipe

Coil types and dimensions:

Jumbo coils: 2800 x 800 mm

Maxi coils: 2800 x 1200 mm

Coil supply:

- as section length, as coils and on drums

- delivered coil length may vary (+/- 5%)

- Sea freight coils: on request

House entry bend

CALPEX-House entry bend 90°

Dimension:	leg length 1,1 x 1,6 m
Carrier pipe:	cross-linked polyethylene (PE-Xa) with oxygen diffusion barrier (heating pipes only)
Insulation:	100% CFC-free polyurethane hard foam (CO ₂)
Protective sheath:	polyethylene (PE-HD)



Bend CPX-QUADRIGA

Dimensions in mm	Art.-No.
H = 25 + 25, S = 28 + 22, A = 142	1013803
H = 32 + 32, S = 28 + 22, A = 142	1013804
H = 32 + 32, S = 32 + 22, A = 142	1013805
H = 40 + 40, S = 40 + 28, A = 162	1013806

Sealing ring

Wall sealing ring

comprising a special section neoprene ring, suitable for

Dimensions in mm	Art.-No.
Outer diameter CALPEX 142	1011601
Outer diameter CALPEX 162	1011602

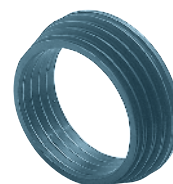

Wall sealing ring

for carottage bored and pipe liner (water pressure tight up to < 0.5 bar)

Dimensions in mm	Art.-No.
Outer diameter CALPEX 142	1009338
Outer diameter CALPEX 162	1011073
Aquagard-Set (Primer)	1010680



For centering we recommend a supplementary sealing ring

Diameter of core holes and pipe liners on page 49

End cap

End cap CPX for dry areas

as termination for house connections, comprising PE-LD

End cap for CALPEX-QUADRIGA, suitable for

Dimensions in mm	Art.-No.
H = 25 + 25, S = 28 + 22, A = 142	1012011
H = 32 + 32, S = 28 + 22, A = 142	1012012
H = 32 + 32, S = 32 + 22, A = 142	1012013
H = 40 + 40, S = 40 + 28, A = 162	1012014

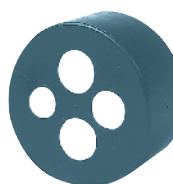

Shrinkable end cap CPX for humid areas

Heat shrinking, as termination for house connections, comprising polymerised and modified polyolefin, coated with sealing adhesive resistant to temperatures up to 125 °C. Including temperature measuring tapes and grinding belt.

End cap for CALPEX-QUADRIGA, suitable for

Dimensions in mm	Art.-No.
H = 25 + 25, S = 28 + 22, A = 142	1012016
H = 32 + 32, S = 28 + 22, A = 142	1012017
H = 32 + 32, S = 32 + 22, A = 142	1012018
H = 40 + 40, S = 40 + 28, A = 162	1012019



Screw connection

Connection piece CPX, screw fittings (nut + ring type)
for connecting two district heating pipes

PEX-connection piece of brass with external thread

PEX-connection piece with weld-on end St 37.0 steel

Heating page 15, Sanitary page 25

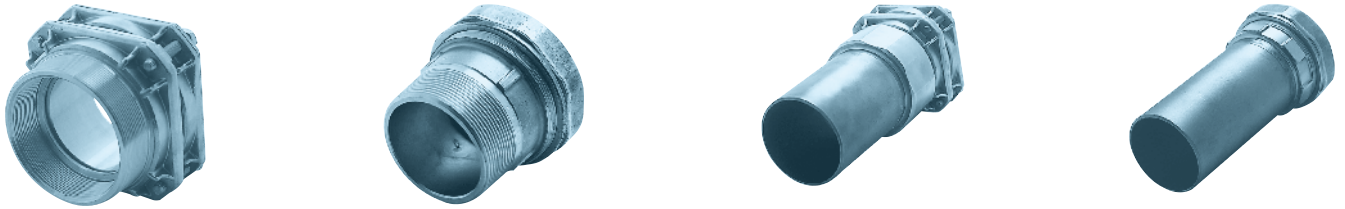

Coupling CPX, equal/reduced, screw connection piece
of brass for connecting two CALPEX district heating pipes

CALPEX-coupling, equal

CALPEX-coupling, reduced

Heating page 15, Sanitary page 25

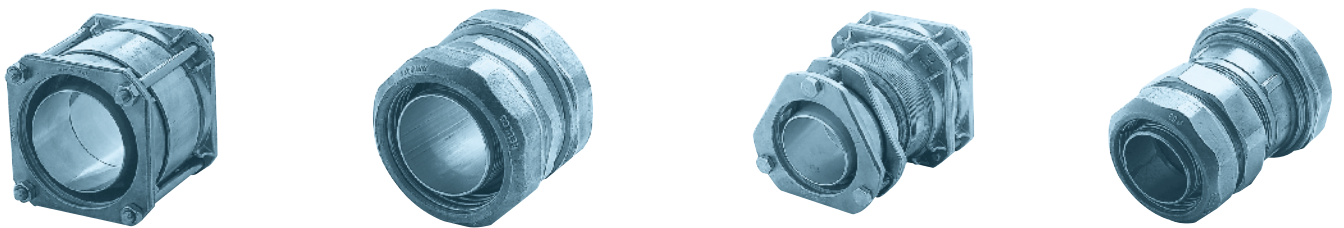

For sockets in the earth we recommend press connections

Press connection

Connection piece CPX, press fittings (sliding sleeve type)

for connecting two district heating pipes

PEX-connection piece of brass with external thread

PEX-connection piece with weld-on fitting St 37.0 steel

Heating page 18, Sanitary page 26



Coupling CPX, equal/reduced, press connection piece

of brass for connecting two CALPEX-district heating pipes

CALPEX-coupling, equal

CALPEX-coupling, reduced

Heating page 18, Sanitary page 26

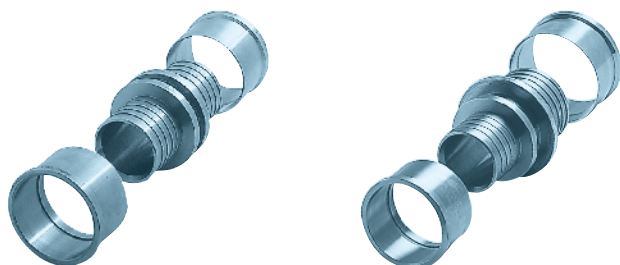

For the system CALPEX-QUADRIGA we recommend connection pieces and couplings with press connection

T-branch, heating / sanitary range

CPX-T, UNO and DUO (Ø 76–126 mm)

Comprising: 2 ABS-half shell with/without plug hole, sealing rings, closing clamps (POM), venting plugs (ABS), 1 glue, installation instructions, foam bottles
 Insulation: CFC-free polyurethane foam bottled
 Note: for T-branches in earth and CALPEX-DUO we recommend press connections only



CPX-T

for CALPEX-UNO / -DUO (heating / sanitary) with polyurethane foam package and sealing rings, suitable for

Dimensions in mm					
d1/d3	d2:	76	91	111	126
76/ 76		1012478	-	-	-
91/ 91		1012482	1012483	-	-
91/ 76		1012479	1012482	-	-
111/111		1012487	1012488	1012490	-
111/ 91		1012486	1012484	1012488	-
111/ 76		1012480	1012486	1012487	1012491
126/126		1012494	1012495	1012496	1012497
126/111		1012491	1012489	1012492	1012496
126/ 91		1012493	1012485	1012489	1012495
126/ 76		1012481	1012493	1012491	1012494

CPX-I

for CALPEX-UNO / -DUO (heating / sanitary) with polyurethane foam package and sealing rings, suitable for

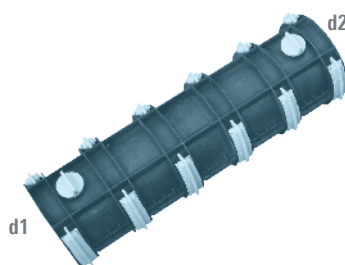

Dimensions in mm		Art.-No.
d1/d2		
76/ 76		1012520
91/ 91		1012522
91/ 76		1012521
111/111		1012524
111/ 91		1012523
126/126		1012526
126/111		1012525

CPX-L

for CALPEX-UNO / -DUO (heating / sanitary) with polyurethane foam package and sealing rings, suitable for

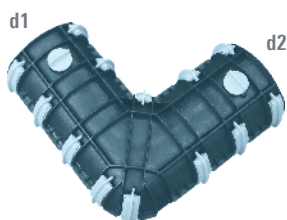

Dimensions in mm		Art.-No.
d1/d2		
76/ 76		1012534
91/ 91		1012535
111/111		1012536
126/126		1012537

Not applicable for CALPEX-QUADRIGA!

Spare parts for CPX-T, -I, -L

Article	Type	Dimensions in mm	CPX-T	CPX-I	CPX-L
			Art.-No.	Art.-No.	Art.-No.
Sealing ring 1	A	76	1010415	1010415	1010415
Sealing ring 2	A	91	1010416	1010416	1010416
Sealing ring 3	B	111	1010417	1010417	1010417
Sealing ring 4	B	126	1009249	1009249	1009249
Packing unit without sealing rings			1012542	1012548	1012546

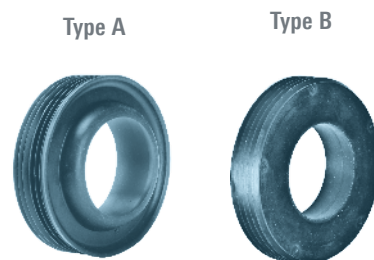

CPX-Big-T, type UNO and DUO (Ø 76 – 182 mm)

Comprising: 2 ABS-half shell with/without plug hole, 3 sealing rings, 27 closing clamps (POM), 3 venting plugs (ABS), 1 glue, installation instructions, foam bottles

Insulation: CFC-free polyurethane foam bottled

Note: for T-branches in earth and CALPEX-DUO we recommend press connections only

CPX-Big-T

for CALPEX-UNO/-DUO heating/sanitary with polyurethane foam package and sealing rings, suitable for

Dimensions in mm

d1/d3	d2:	76	91	111	126	142	162	182
142/ 76		1012554	1012555	1012557	1012560	1012564	-	-
142/ 91		1012555	1012556	1012558	1012561	1012565	-	-
142/111		1012557	1012558	1012559	1012562	1012566	-	-
142/126		1012560	1012561	1012562	1012563	1012567	-	-
142/142		1012564	1012565	1012566	1012567	1012568	-	-
162/ 76		1012569	1012570	1012572	1012575	1012579	1012584	-
162/ 91		1012570	1012571	1012573	1012576	1012580	1012585	-
162/111		1012572	1012573	1012574	1012577	1012581	1012586	-
162/126		1012575	1012576	1012577	1012578	1012582	1012587	-
162/142		1012579	1012580	1012581	1012582	1012583	1012588	-
162/162		1012584	1012585	1012586	1012587	1012588	1012589	-
182/ 76		1012590	1012591	1012593	1012596	1012600	1012605	1012611
182/ 91		1012591	1012592	1012594	1012597	1012601	1012606	1012612
182/111		1012593	1012594	1012595	1012598	1012602	1012607	1012613
182/126		1012596	1012597	1012598	1012599	1012603	1012608	1012614
182/142		1012600	1012601	1012602	1012603	1012604	1012609	1012615
182/162		1012605	1012606	1012607	1012608	1012609	1012610	1012616
182/182		1012611	1012612	1012613	1012614	1012615	1012616	1012617

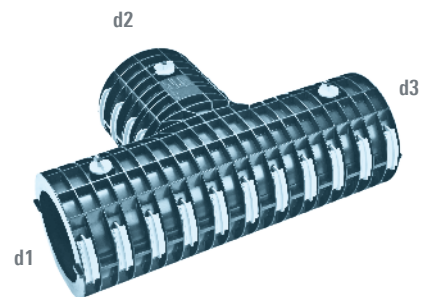

Not applicable for CALPEX-QUADRIGA, connecting chamber on page 43

CPX-Big-I

for CALPEX-UNO / -DUO (heating / sanitary) with polyurethane foam package and sealing rings, suitable for

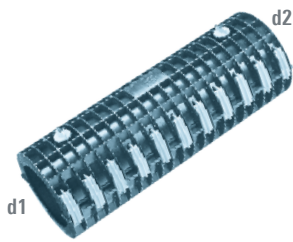

Dimensions in mm	
d1/d2	Art.-No.
142/126	1012628
142/142	1012629
162/142	1012631
162/162	1012632
182/162	1012634
182/182	1012635

CPX-Big-L

for CALPEX-UNO / -DUO (heating / sanitary) with polyurethane foam package and sealing rings, suitable for

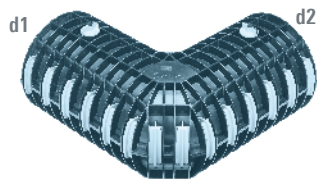

Dimensions in mm	
d1/d2	Art.-No.
142/142	1012620
162/162	1012623
182/182	1012626

Spare parts for CPX-Big-T, -I, -L

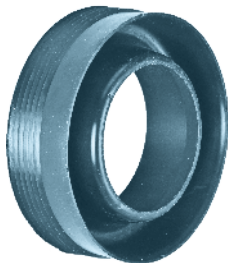

Article	Dimensions	CPX-Big-T	CPX-Big-I	CPX-Big-L
	in mm	Art.-No.	Art.-No.	Art.-No.
Sealing ring 1	76	1009659	1009659	1009659
Sealing ring 2	91	1009660	1009660	1009660
Sealing ring 3	111	1009661	1009661	1009661
Sealing ring 4	126	1009662	1009662	1009662
Sealing ring 5	142	1009663	1009663	1009663
Sealing ring 6	162	1009664	1009664	1009664
Sealing ring 7	182	1009665	1009665	1009665
Packing unit without sealing rings		1012545	1012551	1012553

Not applicable for CALPEX-QUADRIGA, connecting chamber on page 43

CALPEX-T-piece preinsulated

Specification:	carrier pipe St 37.0 incl. press fitting and sliding ring 160 / 250 mm: Branch line bent 45°
Insulation:	100% CFC-free polyurethane hard foam
Protective sheath:	polyethylene (PE-HD)
Note:	connecting sockets are not included in delivery; please note that the insulation of the CPX is thicker (Ø 200 mm / Ø 225 mm) and adequate reduction sockets are required



CPX-T-piece preinsulated

Carrier pipe St 37.0 incl. press fitting and sliding ring

Dimensions in mm		25/90 ¹⁾	32/90 ¹⁾	40/110 ²⁾	50/110	63/125
d1/d3	d2:					
125/225 - 125/225 ⁵⁾		1007014	1007015	1007016	1007017	1007018
140/225 - 140/225		1007092	1007093	1007094	1007095	1007096
140/225 - 125/225		1007072	1007073	1007074	1007075	1007076
125/225 - 140/225		1007082	1007083	1007084	1007085	1007086
160/250 - 160/250		1007023	1007024	1007025	1007026	1007027
160/250 - 125/250		1007046	1007047	1007048	1007049	1007050
125/250 - 160/250		1007055	1007056	1007057	1007058	1007059

Dimensions in mm		75/140	90/160	110/200 ³⁾	125/225 ⁴⁾	140/225	160/250
d1/d3	d2:						
125/225 - 125/225 ⁵⁾		1007019	1007020	1007021	1007022	-	-
140/225 - 140/225		1007097	1007068	1007069	1007070	1007071	-
140/225 - 125/225		1007077	1007078	1007079	1007080	1007081	-
125/225 - 140/225		1007087	1007088	1007089	1007090	1007091	-
160/250 - 160/250		1007028	1007029	1007030	1007031	auf Anfrage	1007032
160/250 - 125/250		1007051	1007052	1007053	1007054	auf Anfrage	-
125/250 - 160/250		1007060	1007061	1007062	1007063	auf Anfrage	-

¹⁾ reduction socket Ø 90/76 is required

²⁾ reduction socket Ø 110/91 is required

³⁾ reduction socket Ø 200/162 or 200/182 is required

⁴⁾ reduction socket Ø 225/182 is required

⁵⁾ 2 reduction sockets Ø 225/182 are required

Socket, heating range

CALPEX-Connecting socket set, type CALPEX-CALPEX

Comprising: PE-HD socket pipe (reduced at one side for reducing sockets), two PE-shrinking hoses and a grinding belt
 Insulation: foam package of polyurethane or PE-foam



Connecting socket set CPX-UNO

for CALPEX-UNO Heating with PUR-foam package or PE-foam, suitable for

Dimensions in mm	Art.-No. PUR-foam	Art.-No. PE-foam
76 to 76	1010832	1010810
76 to 91	1010833	1010812
91 to 91	1010823	1010811
91 to 111	1010825	1010814
111 to 111	1010824	1010813
111 to 126	1010827	1010816
126 to 126	1010826	1010815
126 to 142	1010829	1010818
142 to 142	1010828	1010817
142 to 162	1010831	1010819
162 to 162	1010830	1010808
162 to 182	1010928	1000845
182 to 182	1000840	1000846
182 to 202	1000850	-
202 to 202	1011464	-
182 to 250	1000852	-
250 to 250	1000862	-

Connecting socket set CPX-DUO

for CALPEX-DUO Heating with PUR-foam package or PE foam, suitable for



Dimensions in mm	Art.-No. PUR-foam	Art.-No. PE-foam
91 to 91	1010823	1010857
91 to 111	1010825	1010859
111 to 111	1010824	1010858
111 to 126	1010827	1010861
126 to 126	1010826	1010860
126 to 162	1010868	1010856
162 to 162	1010925	1010849
162 to 182	1010928	1000847
182 to 182	1000840	1000848
182 to 202	1000850	-
202 to 202	1011464	-

Socket, sanitary range

CALPEX-Connecting socket set, type CALPEX-CALPEX

Comprising: PE-HD socket pipe (reduced at one side for reducing sockets), two PE-shrinking hoses and a grinding belt
 Insulation: foam package of polyurethane or PE-foam

Connecting socket set CPX-UNO

for CALPEX-UNO Sanitary with PUR-foam package or PE-foam, suitable for

Dimensions in mm	Art.-No. PUR-foam	Art.-No. PE-foam
76 to 76	1010832	1010810
76 to 91	1010833	1010812
91 to 91	1010823	1010811
91 to 111	1010825	1010814
111 to 111	1010824	1010813
111 to 126	1010827	1010816
126 to 126	1010826	1010815



Connecting socket set CPX-DUO

for CALPEX-DUO Sanitary with PUR-foam package or PE-foam, suitable for

Dimensions in mm	Art.-No. PUR-foam	Art.-No. PE-foam
91 to 91	1010823	1010857
91 to 111	1010825	1010859
111 to 111	1010824	1010858
111 to 126	1010827	1010861
126 to 126	1010826	1010860



Connecting socket set CPX-UNO (HCC)

for CALPEX-UNO Sanitary with heating cable channel and PUR-foam package or PE-foam, suitable for

Dimensions in mm	Art.-No. PUR-foam	Art.-No. PE-foam
111 to 111	1010824	1010798
111 to 126	1010827	1010801
126 to 126	1010826	1010800



Socket, CALPEX-KMR range

CALPEX-Connecting socket set, type CALPEX-plastic sheath pipe (KMR)

Comprising: PE-HD socket pipe (reduced at one side for reducing sockets), two PE-shrinking hoses and a grinding belt
 Isolation: foam package of polyurethane or PE-foam



Connecting socket set CPX-KMR

for CALPEX-UNO Heating/Sanitary with PUR-foam package or PE-foam, suitable for

Dimensions in mm	Art.-No. PUR-foam	Art.-No. PE-foam
CALPEX 22/ 76 to plastic sheath pipe 26.9/ 90	1010833	1010892
CALPEX 22/ 76 to plastic sheath pipe 26.9/110	1010929	1010904
CALPEX 22/ 76 to plastic sheath pipe 26.9/125	1010934	1010918
CALPEX 25/ 76 to plastic sheath pipe 26.9/ 90	1010833	1010892
CALPEX 25/ 76 to plastic sheath pipe 26.9/110	1010929	1010904
CALPEX 25/ 76 to plastic sheath pipe 26.9/125	1010934	1010918
CALPEX 28/ 76 to plastic sheath pipe 26.9/ 90	1010833	1010892
CALPEX 28/ 76 to plastic sheath pipe 26.9/110	1010929	1010904
CALPEX 28/ 76 to plastic sheath pipe 26.9/125	1010934	1010918
CALPEX 32/ 76 to plastic sheath pipe 33.7/ 90	1010833	1010892
CALPEX 32/ 76 to plastic sheath pipe 33.7/110	1010929	1010904
CALPEX 32/ 76 to plastic sheath pipe 33.7/125	1010934	1010918
CALPEX 40/ 91 to plastic sheath pipe 42.4/110	1010825	1010814
CALPEX 40/ 91 to plastic sheath pipe 42.4/125	1010931	1010906
CALPEX 40/ 91 to plastic sheath pipe 42.4/140	1010936	1010919
CALPEX 50/111 to plastic sheath pipe 48.3/110	1010824	1010894
CALPEX 50/111 to plastic sheath pipe 48.3/125	1010827	1010907
CALPEX 50/111 to plastic sheath pipe 48.3/140	1010937	1010920
CALPEX 63/126 to plastic sheath pipe 60.3/125	1010826	1010815
CALPEX 63/126 to plastic sheath pipe 60.3/140	1010829	1010908
CALPEX 63/126 to plastic sheath pipe 60.3/160	1010868	1010921
CALPEX 75/142 to plastic sheath pipe 76.1/140	1010927	1010895
CALPEX 75/142 to plastic sheath pipe 76.1/160	1010831	1010909
CALPEX 75/142 to plastic sheath pipe 76.1/180	1010938	1010922
CALPEX 90/162 to plastic sheath pipe 88.9/160	1010925	1010891
CALPEX 90/162 to plastic sheath pipe 88.9/180	1010928	1010903
CALPEX 90/162 to plastic sheath pipe 88.9/200	1010933	1010916
CALPEX 110/162 to plastic sheath pipe 114.3/200	1010933	1010948
CALPEX 110/162 to plastic sheath pipe 114.3/225	1010951	1010949
CALPEX 110/162 to plastic sheath pipe 114.3/250	1010952	1010950
CALPEX 110/182 to plastic sheath pipe 114.3/200	1000850	1000856
CALPEX 110/182 to plastic sheath pipe 114.3/225	1000851	1000857
CALPEX 110/182 to plastic sheath pipe 114.3/250	1000852	1000858
CALPEX 125/182 to plastic sheath pipe 139.7/200	1000850	-
CALPEX 125/182 to plastic sheath pipe 139.7/225	1000851	-
CALPEX 125/182 to plastic sheath pipe 139.7/250	1000852	-
CALPEX 140/202 to plastic sheath pipe 139.7/225	1011463	-
CALPEX 140/202 to plastic sheath pipe 139.7/250	1011462	-
CALPEX 140/202 to plastic sheath pipe 139.7/280	1011461	-
CALPEX 160/250 to plastic sheath pipe 168.3/250	1000862	-
CALPEX 160/250 to plastic sheath pipe 168.3/280	1000864	-
CALPEX 160/250 to plastic sheath pipe 168.3/315	1000866	-

Sockets without insulating material

CALPEX-Connecting Set, type CALPEX-Plastic sheath pipe (KMR)

Comprising: PE-HD socket pipe (reduced at one side for reducing sockets), two PE-shrinking hoses and a grinding belt

Connecting socket set CPX-KMR

for CALPEX-UNO Heating/Sanitary, without insulating material, suitable for

Dimensions in mm	Art.-No.
CALPEX 76 to plastic sheath pipe 90	1010764
CALPEX 76 to plastic sheath pipe 110	1010842
CALPEX 76 to plastic sheath pipe 125	1010872
CALPEX 91 to plastic sheath pipe 90	1010758
CALPEX 91 to plastic sheath pipe 110	1010765
CALPEX 91 to plastic sheath pipe 125	1010855
CALPEX 91 to plastic sheath pipe 140	1010875
CALPEX 111 to plastic sheath pipe 90	1010765
CALPEX 111 to plastic sheath pipe 110	1010759
CALPEX 111 to plastic sheath pipe 125	1010766
CALPEX 111 to plastic sheath pipe 140	1010876
CALPEX 126 to plastic sheath pipe 110	1010766
CALPEX 126 to plastic sheath pipe 125	1010760
CALPEX 126 to plastic sheath pipe 140	1010769
CALPEX 126 to plastic sheath pipe 160	1010770
CALPEX 142 to plastic sheath pipe 125	1010769
CALPEX 142 to plastic sheath pipe 140	1010835
CALPEX 142 to plastic sheath pipe 160	1010763
CALPEX 142 to plastic sheath pipe 180	1010877
CALPEX 162 to plastic sheath pipe 140	1010763
CALPEX 162 to plastic sheath pipe 160	1010821
CALPEX 162 to plastic sheath pipe 180	1010841
CALPEX 162 to plastic sheath pipe 200	1010870
CALPEX 162 to plastic sheath pipe 225	1010953
CALPEX 162 to plastic sheath pipe 250	1010954
CALPEX 182 to plastic sheath pipe 160	1010841
CALPEX 182 to plastic sheath pipe 180	1000849
CALPEX 182 to plastic sheath pipe 200	1000859
CALPEX 182 to plastic sheath pipe 225	1000860
CALPEX 182 to plastic sheath pipe 250	1000861
CALPEX 250 to plastic sheath pipe 250	1000863
CALPEX 250 to plastic sheath pipe 280	1000865
CALPEX 250 to plastic sheath pipe 315	1000867



CALPEX-Connecting socket set, type CALPEX-CALPEX

Comprising: PE-HD socket pipe (reduced at one side for reducing sockets), two PE-shrinking hoses and a grinding belt



Connecting socket set CPX-CPX

for CALPEX Heating/Sanitary without insulating material, suitable for

Ø Casing in mm	UNO	DUO	QUADRIGA
76 to 76	1010757	-	-
76 to 91	1010764	-	-
91 to 91	1010758	1010758	-
91 to 111	1010765	1010765	-
111 to 111	1010759	1010759	-
111 to 126	1010766	1010766	-
126 to 126	1010760	1010760	-
126 to 142	1010769	-	-
142 to 142	1010761	1010761	1010763
142 to 162	1010763	1010763	-
162 to 126	-	1010770	-
162 to 162	1010762	1010821	1010841
162 to 182	1010841	1010841	-
182 to 182	1000849	1000849	-
182 to 250	1000861	-	-
250 to 250	1000863	-	-

Insulation with PUR component foam



Accessories

Connecting chamber

comprising a chamber, cap, screws, subject disks, nuts and assembly instruction

Article	Art.-No.
Connecting chamber CPX 25/76 - 125/182	1011794

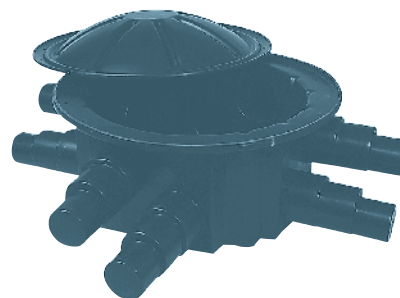

Entry sealing

for connecting chamber comprising shrinking hoses, grinding belt to the dimensions with outer diameter 76, 91, 126 and 162 with centering ring

Dimensions in mm	Art.-No.
for outer diameter CALPEX 76	1011800
for outer diameter CALPEX 91	1011799
for outer diameter CALPEX 111	1011798
for outer diameter CALPEX 126	1011797
for outer diameter CALPEX 142	1011796
for outer diameter CALPEX 162	1011795
for outer diameter CALPEX 182	1000885

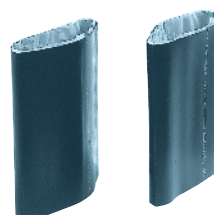

Leasable tool kits for press connection

comprising tool box (expansion tool and press tool)

Article	Art.-No.
Manual press tool \varnothing 22 - 40 mm	1013801
Hydraulic expansion tool \varnothing 50 - 110 mm	1013802
Hydraulic press yoke \varnothing 50 - 110 mm	1013798
Both tool boxes are necessary	



Article	Art.-No.
Electrohydraulic expansion tool \varnothing 125, 160 mm	1013799
Hydraulic press yoke \varnothing 125, 160 mm	1013800
Electrohydraulic expansion tool \varnothing 140 mm	1013799
Hydraulic press yoke \varnothing 140 mm	1013781
Both tool boxes are necessary	

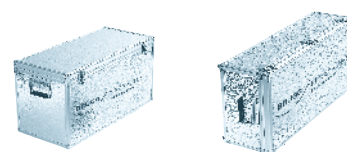

Leasable tool kits for electrofusion fitting for PEXa pipes

comprising welding tool and clamps

Article	Art.-No.
Tool set without pipe cutter	1013777
Additional pipe clamps	1013778
Pipe cutter \varnothing 50-125 mm	1011605
Pipe cutter \varnothing 110-160 mm	1011308

The electrofusion fittings are installed exclusively by certified fitters!



Trench warning tape CPX

with imprint «Caution district heating pipe»

Article	Art.-No.
Warning tape (length customised)	1008472



Checklist

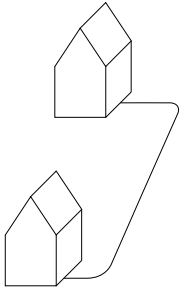

Example 1: House-house connection

With CALPEX-UNO		With CALPEX-DUO	
Quantity	Material	Quantity	Material
2	Single-line pipes CPX-UNO	1	Twin-line pipe CPX-DUO
4	Sealing rings CPX or	2	Sealing rings CPX or
4	Wall sealing rings	2	Wall sealing rings
4	End caps CPX for dry areas or	2	End caps CPX for dry areas or
4	Shrinking end caps CPX for wet areas	2	Shrinking end caps CPX for wet areas
4	Connection pieces CPX, screw connection or	4	Connection pieces CPX, screw connection or
4	Connection pieces CPX, press connection	4	Connection pieces CPX, press connection
1	Trench warning tape	1	Trench warning tape

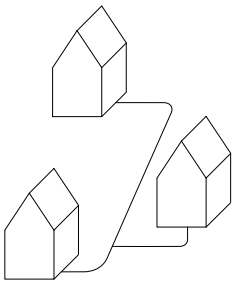

Example 2: House-house connection with branch line

With CALPEX-UNO		With CALPEX-DUO	
Quantity	Material	Quantity	Material
6	Single-line pipes CPX-UNO	3	Twin-line pipes CPX-DUO
6	Sealing rings CPX or	3	Sealing rings CPX or
6	Wall sealing rings	3	Wall sealing rings
6	End caps CPX for dry areas or	3	End caps CPX for dry areas or
6	Shrinking end caps CPX for wet areas	3	Shrinking end caps CPX for wet areas
6	Connection pieces CPX, screw connection or	6	Connection pieces CPX, screw connection or
6	Connection pieces CPX, press connection	6	Connection pieces CPX, press connection
2	T-pieces CPX-UNO, press connection	2	T-pieces CPX-UNO, press connection
2	Installation CPX T-piece or	1	Installation CPX T-piece or
1	Connecting chamber shrinking hoses	1	Connecting chamber shrinking hoses
1	Trench warning tape	1	Trench warning tape

Installation tools

The installation instruction is one of the most important tools!

Basic tool	Working steps
Saw	Cutting the sheathed pipe and insulation
Sharp knife	Removing the insulation
Plastic or rubber mallet	Auxiliary tool
Gas burner	For all shrinking tasks
Cleaning agent and cloth	Cleaning the casing
2 adjustable spanners	Tightening the cap nut/holding of the connections in case of PEX-screw connections
Drill machine and pin drill	When operating with sockets, drilling the hole where to fill in the foam
Gloves	When operating with gas burner
Goggles	Protection of the eyes while operating with PUR-foam cartridge



Transport

Max. delivery height	2800 mm
Max. delivery width	1200 mm
Max. delivery length	up to 1000 m depending on dimension
Delivery weight	0.90 – 6.38 kg/m
Accessories	cardboard-packs

When using a fork-lift to unload the rings, the forks should be protected in order to avoid cutting into the pipe casing.



Storage

Before laying, pipes must be stored at min. 5°C
Do not remove protective caps before laying
Store dry cardboard with accessories

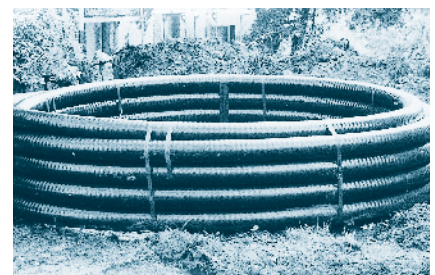

Trench space dimensions

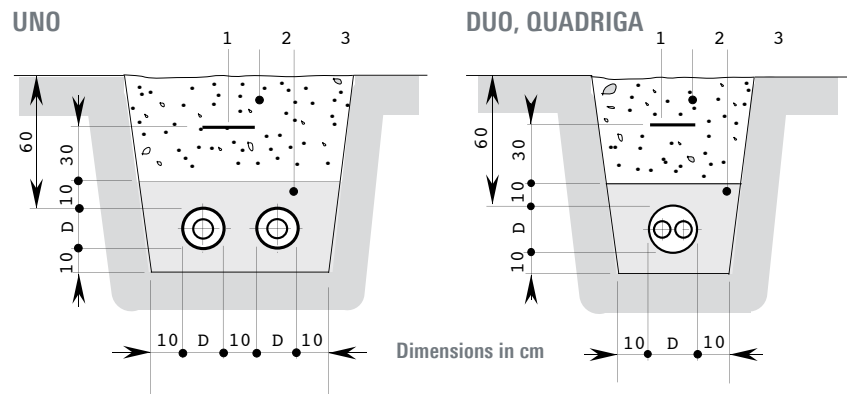

Trench section

Any projecting stones and rocks in the trench must be removed.

1	Trench warning tape
2	Excavated material
3	Sand washed, grain size 0–8 mm

Covering height: Max. covering height: 2.6 m, higher covering needs advise from Brugg Rohrsysteme. SLW 30 = 300 kN wheel load DIN 1072; for bigger loads (e.g. SLW 60) a load distribution superstructure according RSt075 is required. Without traffic load the minimum covering height may be reduced by 20 cm.

Laying

Do **not** roll the CALPEX-ring out over edges, and do **not** pull the unrolled pipe over long distances on the asphalt. This can cause damage to the protective polyethylene casing. Damaged points on the casing can be repaired, using the shrink socket.

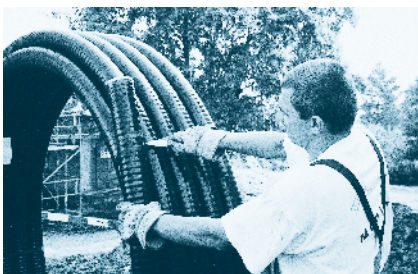

1. Place the CALPEX-ring at the start of the line, and cut the outermost fixing tape.



2. Unroll the ring as far as the next fixing tape; only now should you cut the next fixing tape.



3. Repeat this procedure until the ring has been unrolled.

IMPORTANT!

CALPEX coils are under tension! Don't cut all the fixing tapes together!

Uncontrolled release of the tension in the coils is **DANGEROUS** (spring effect).

Aligning the pipe ends

If necessary (e.g. if the laying temperature is low, or the pipe diameter is large) curved pipe ends can be bent straight with the help of an aligning rail.



1. Fix the CALPEX-pipe to one end of the rail, using the tensioning belt.



2. Fix the CALPEX-pipe to the other end of the rail.



3. Use hot air or hot water to heat the medium pipe; let it cool – and the job is finished.

Estimated installation time for CALPEX

Estimated installation time for CALPEX

Laying of CALPEX-district heating pipes in open trenches

Ø sheath mm	Dimensions of coils m	Number of fitters	CPX-UNO min	CPX-DUO min
76 – 91	25	2	20	-
	50	2	35	-
	75	2	50	-
111 – 126	25	2 – 3	25	25
	50	3	40	40
	75	3	55	55
142	30	4	30	30
	70	4	65	65
162	30	4 – 5	40	40
	70	4 – 5	75	75
182	30	4 – 5	45	45
	70	by truck	85	85
202	30	4 – 5	45	45
	70	by truck	85	85

House connection

PEX-coupling, end cap, sealing ring

Dimension of sheat mm	Number of fitters	CPX-UNO min	CPX-DUO min
76–126	1	20	30
142	1	30	-
162	1	40	-
182	1	45	-

Insulation

Socket connection incl. PEX-coupling

Dimension of sheat mm	Number of fitters	CPX-UNO min	CPX-DUO min
76–126	1–2	60	75
142–162	1–2	70	-
182–250	1–2	80	-

GFK-T-piece up to DN 100

incl. PEX-T-coupling

Dimension of sheat mm	Number of fitters	CPX-UNO min	CPX-DUO min
76–126	1–2	35	55
142–182	1–2	40	60
250	1–2	180	-

A special tool set is required for press connections

- Ø 22–40: Tool consisting of 1 box
- Ø 50–110: Tool consisting of 2 boxes
- Ø 125 + 160: Tool consisting of 2 boxes
- Ø 140: Tool consisting of 2 boxes

Not included are:

- Travel time
- Pressure test
- Welding of connection and T-pieces

The estimated time may vary according to the individual situation at site (site conditions, condition of trenches, existing pipelines in ground, weather conditions, etc.)



Building entry

Wall entry/breakthrough bored for wall sealing ring (Neopren)

∅ Protective sheath in mm	L min in mm	H in mm
78	450	250
93	500	250
113	500	300
128	550	300
143	600	350
163	650	350
183	670	380
202	720	400
225	740	400
250	810	450

∅ Protective sheath in mm	A in mm	D1 in mm
78	210	180
93	230	180
113	250	220
128	270	230
143	290	230
163	310	280
183	330	280
202	400	350
225	400	350
250	420	380

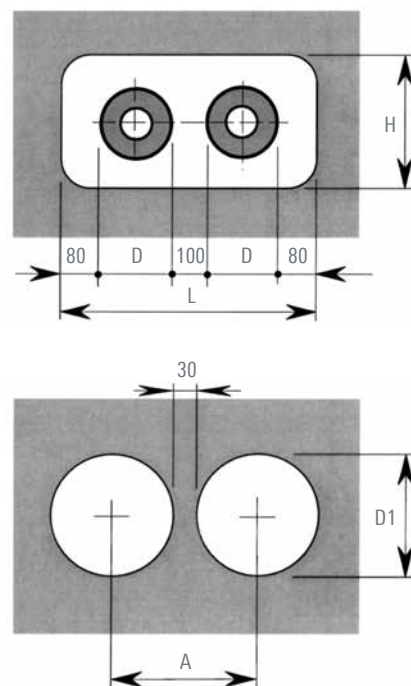

Wall entry/breakthrough bored for wall sealing ring (compressible)

Prerequisites for installation are perfect drill holes. Since hairline cracks can exist in concrete or can arise as a result of the work, we recommend sealing the hole over the entire length with a sealant (e.g. AQUAGARD).

Tightness can only be guaranteed if this recommendation is followed.

∅ Casing mm	Pipe liner core drilling mm	Sealing set ∅ inside in mm	Sealing set ∅ outside in mm
76	150	78 - 85	150
91	150	86 - 94	150
111	200	105 - 115	200
126	200	125 - 135	200
142	200	137 - 145	200
162	250	157 - 165	250
182	250	180 - 190	250
202	300	198 - 207	300
225	300	225 - 233	300
250	350	250 - 259	350

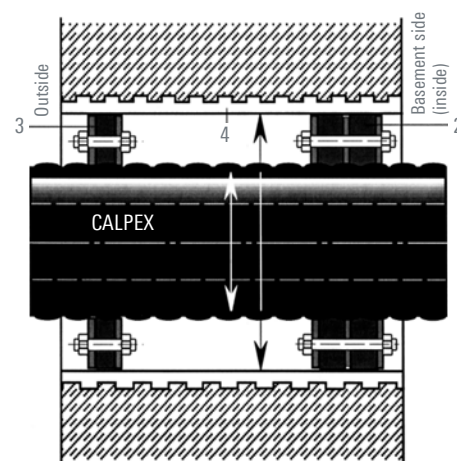

- 1 CALPEX-district heating pipe
- 2 Sealing set double-sealing, width 2 x 40 mm, Shore hardness 35
- 3 Sealing set (centering), width 1 x 20 mm
- 4 Pipe liner made of fibre cement or coated core bore

Wall sealing rings heating range page 13 / Wall sealing rings sanitary range page 24

House connection

Connection with male thread

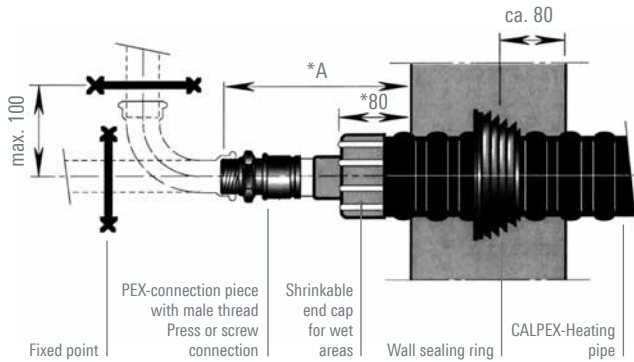

* Dimensions may be reduced by max. 60 mm when end cap is walled in.

Dimensions mm	Press connection Length A in mm	Screw connection Length A in mm
25/ 76	260	210
32/ 76	260	220
40/ 91	270	220
50/111	270	220
63/126	320	230
75/142	320	235
90/162	330	260
110/182	340	270
125/182	340	-
140/202	-	-
160/250	340	-

Sanitary, 10 bar

22/ 76	260	210
28/ 76	260	210
32/ 76	260	220
40/ 91	270	220
50/111	270	220
63/126	320	230

Connection with weld-on end

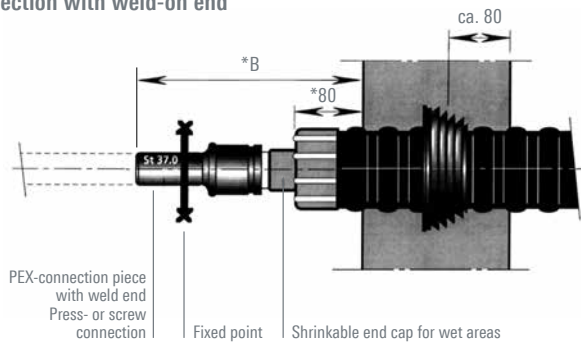

* Dimensions may be reduced by max. 60 mm when end cap CPX is used for dry areas.

Dimensions mm	Press connection Length A in mm	Screw connection Length A in mm
25/ 76	250	340
32/ 76	250	340
40/ 91	260	340
50/111	270	360
63/126	310	340
75/142	310	340
90/162	310	410
110/182	310	450
125/182	310	-
140/202	340	-
160/250	340	-

Resulting fix point forces for CALPEX-pipe

CALPEX-Heating, 6 bar

Max. resulting fix point forces for each pipe at:

$T_B = 90\text{ °C}, p_B = 6\text{ bar}$		
Dimensions in mm		Fmax (N)
25/ 76	25/ 91 PLUS	924
32/ 76	32/ 91 PLUS	1493
40/ 91	40/111 PLUS	2367
50/111	50/126 PLUS	3686
63/126	63/142 PLUS	5782
75/142	75/162 PLUS	8205
90/162	90/182 PLUS	11864
110/182	110/202 PLUS	17675
125/182	125/202 PLUS	22888
140/202		28747
160/250		37502

$T_B = 60\text{ °C}, p_B = 6\text{ bar}$		
Dimensions in mm		Fmax (N)
25/ 76		640
32/ 76		1036
40/ 91		1639
50/111		2553
63/126		4013
75/142		5693
90/162		8228
110/182		12260
125/182		15872
140/202		19928
160/250		26004

CALPEX-Sanitary, 10 bar

Max. resulting fix point forces for each pipe at:

$T_B = 60\text{ °C}, p_B = 6\text{ bar}$		
Dimensions in mm		Fmax (N)
22/ 76		820
28/ 76		1350
32/ 76		1730
40/ 91		2700
50/111		4230
63/126		6715

Installation instructions CALPEX

Stripping, pipe-preparation

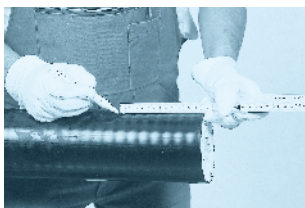

1. Mark the distance (x, y, z) + 1 cm from the end of the pipe.

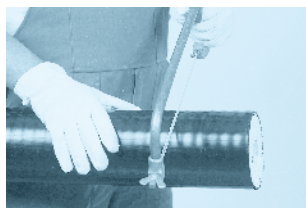

2. Cut the jacket with a pipe-cutter or a saw at the marked distance from the end of the pipe.

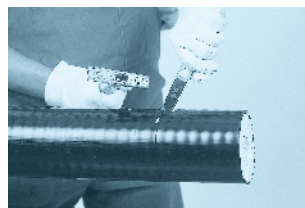

3. Open the jacket longitudinally. Knife max. 5 mm deep into foam.



4. Remove jacket.

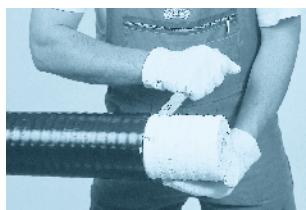

5. Cut back insulation over the marked distance.
Attention: Service-pipe with barrier of EVOH! Be careful!



6. Mount the wall seal. Stretch the clip (if existing).

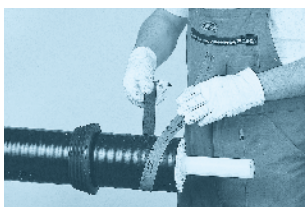

7. Grind protective sheath.

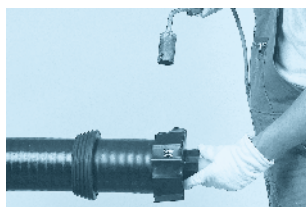

8. Carefully put end cap CPX for below ground onto the pipe according to the enclosed Raychem DHEC installation instruction or attach end cap CPX for above ground.



9. Cut the PEX-Pipe square to its axis (max. 1 cm).

Stripping length (x, y, z) see drawing on page 53

Stripping length for screw connections

UNO

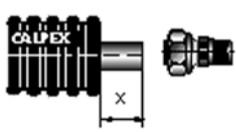

Ø 22-75 mm
X = 90 mm
Ø 90, 110 mm
X = 140 mm

DUO

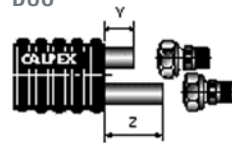

Ø 22-63 mm
Y = 80 mm
Z = 180 mm

QUADRIGA

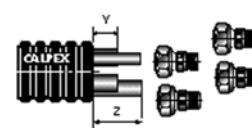

Heizung
Y = 110 mm
Sanitär
Z = 200 mm

Stripping length for press connections

UNO

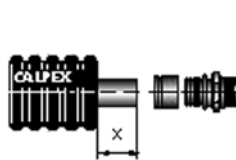

Ø 22-50 mm
X = 140 mm
Ø 63 - 125 mm
X = 180 mm

DUO

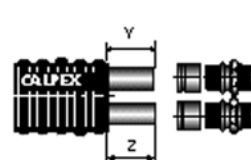

Ø 22-75 mm
Y, Z = 140 mm
Y, Z = 160 mm

QUADRIGA

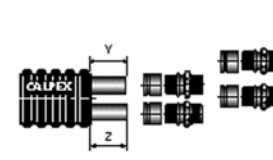

Y = 140 mm
Z = 140 mm

Installation instructions for connections

Screw connections

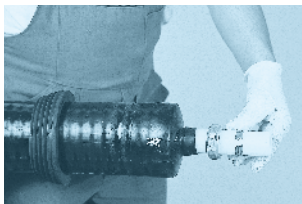

1. Put the union nut and the clamping ring onto the pipe.

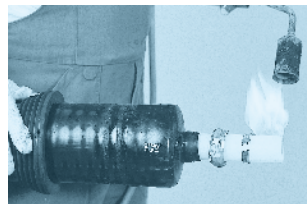

2. Heat PEX-pipe up to 60 °C.

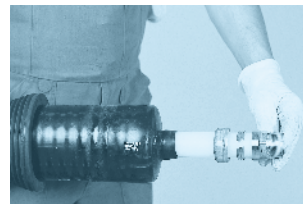

3. Push the muff as far as the base of the recess.

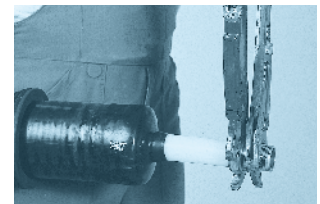

4. Move the union nut, the clamping ring and the muff together, and tighten them adequately. Caution: Do not overtighten!

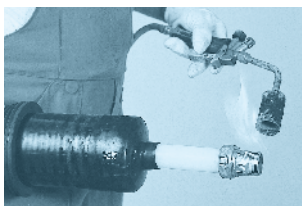

5. Heat the Beulco fitting to 60–80 °C again.

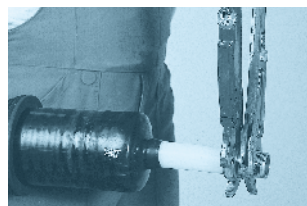

6. Retighten the fitting. Caution: Do not overtighten!

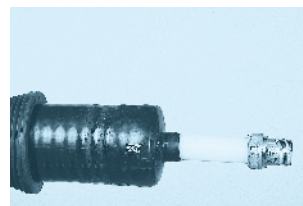

7. The job is finished!

Press connections

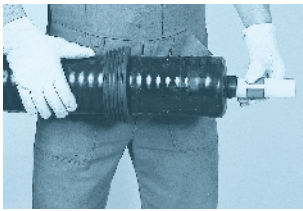

1. Push the sliding sleeve over the pipe; the inner ridge must point to the end of the pipe (with the conical end of the sliding sleeve towards the end of the pipe).

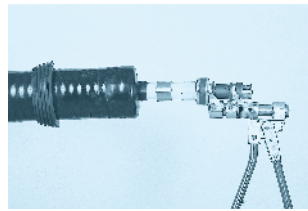

2. Widen the pipe twice, with a 30° offset; the sliding sleeve must not be located in the widened zone.

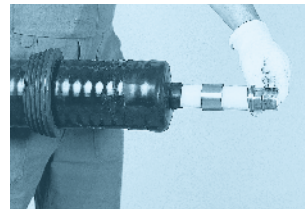

3. Insert the fitting in the pipe, and the fitting will "sit" firmly in the pipe after a short while (memory effect).

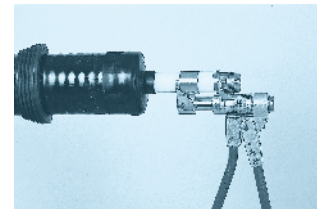

4. Apply the tool; do not tilt.



5. Move the selector button to the slide position.

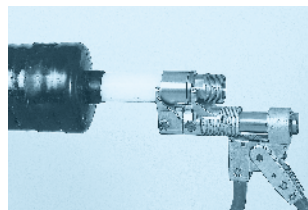

6. With levering movements, push the slider sleeve as far as the collar of the fitting.

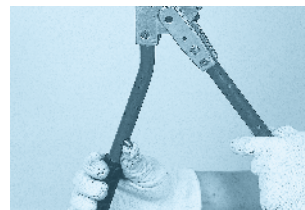

7. Move the selector button to the reset position.

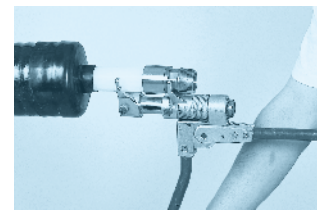

8. Press the levers together again, then swivel the movable lever upwards by 90° to move the tool into its initial position.

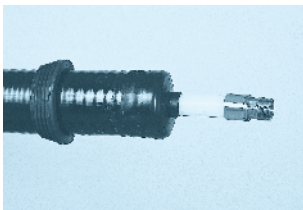

9. The job is finished!

Fitting instruction - chamber



1. Saw the shaft mouth to match the outer diameter of the pipe – \varnothing 136, 166 or 186 mm are possible.



2. Pull the shrink hose over the pipe ends.



3. Fit the two-section reducer ring (only needed for CPX dimensions 76, 91 and 126 mm).



4. Grind the shaft mouths.

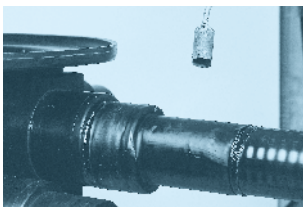

5. Remove the protective film from the shrink hose and heat-shrink.
Filling/insulation material:
– polystyrene fragments
– Armaflex or Tubolit



6. Screw the shaft together with the cover, including the sealing ring (screws, washers and nuts are supplied).

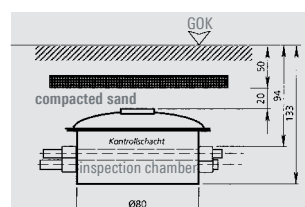

7. A pressure distribution plate must be used wherever there could be public traffic. The maximum surface load must not exceed $q = 153 \text{ kN/m}^2$ (SLW 60 to DIN 1055).

Installation instructions, T-Shell and connecting chamber

CALPEX-T-Shell and CALPEX-Big-T

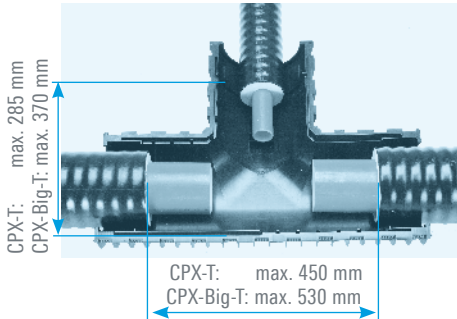

1. Strip the insulation from the pipes.

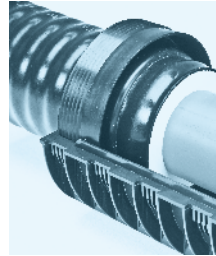

2. Pull all the sealing rings over the pipe end. The sealing lips must be facing the stripped end.

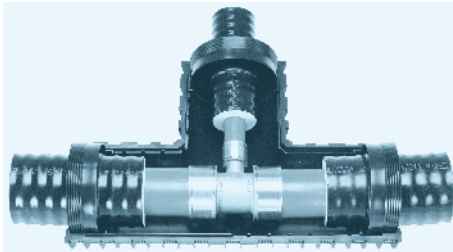

3. Connect the pipes according to the installation instructions.

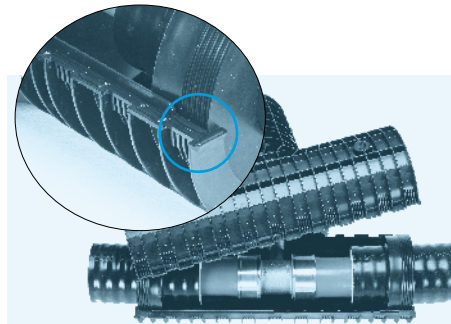

4. Position the sealing rings precisely. The front faces must be in contact. Check the fit of the upper shell.

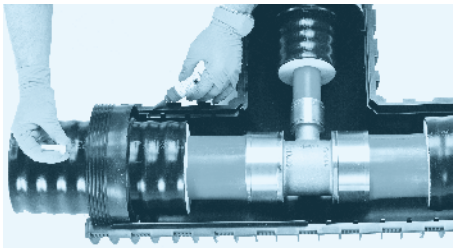

5. Clean all gluing surfaces so that they are free from grease, then apply a continuous line of adhesive, about 4 mm (1/8 inch) wide, to the lower shell only.

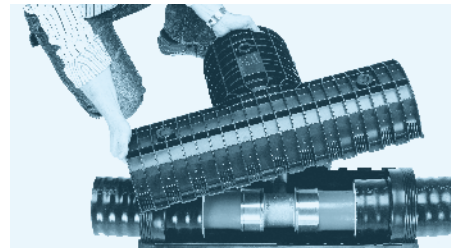

6. Now place the upper shell on top.

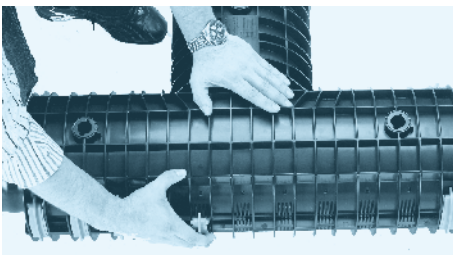

7. Immediately apply all the clamps at the positions provided for them, and allow the glue to harden for **20 minutes**.



8. Prepare the enclosed foam kit according to the instructions and pour the foam into the shell.



9. Allow at least **5 min**, seal with the rubber stoppers.

Not applicable for CALPEX-QUADRIGA!

Pressure and leak-tightness test

1. Principles of the pressure test

The successful conducting and documentation of a pressure test is a requirement for any claims as part of the Brugg Pipesystems warranty.

For safety reasons it is recommended to carry out the pressure testing of the heating network with water.

Testing with compressed air is associated with considerable risks due to the high pipe volume.

According to DIN EN 806-4 and DIN 1988, a pressure test must be carried out on the finished but not yet covered pipes prior to commissioning.

Statements concerning the leaktightness of the system based on the test pressure course (constant, dropping, increasing) can only be made conditionally.

- The leaktightness of the system can only be checked by way of a visual inspection of uncovered pipes.
- Small leaks can only be located by way of a visual inspection (water coming out) at high pressure.

Dividing the heating network system into smaller test sections increases the accuracy of the testing.

2. Leak-tightness testing with water

Preparing the pressure test with water

- Pipes must be accessible and must not be covered
- Dismantle safety and counting devices where required and replace with pipe pieces or pipe end stops
- Fill pipes from the deepest point of the system, excluding any air, with filtered drinking water. Here the water must match the ambient temperature ($\Delta v \leq 10$ K ambient temperature to water temperature)
- Bleed the draw-off points until no air can be determined in the expelled water
- Use a pressure testing device with an accuracy of 100 hPa (0.1 bar) for the pressure test
- Connect the pressure testing device at the deepest point of the heating network system
- Carefully close all draw-off points
- Make sure that the temperature remains as constant as possible during the pressure test
- Prepare the pressure test record sheet and note the system data

The pressure test can be heavily influenced by temperature changes in the pipe system, e.g. a temperature change of 10 K can cause a pressure change of 0.5 to 1 bar.

Due to the pipe material properties (e.g. pipe elongation with increasing pressurisation) a pressure fluctuation can occur during the pressure test.

The pressure test as well as the pressure course that occurs during the test does not allow any sufficient conclusions to be drawn on the leaktightness of the system. The entire installation, as stipulated in the standards, is therefore to be checked for leaktightness by way of a visual inspection.

Pressure test for systems with CALPEX pipes

Pressure test diagram for CALPEX pipes

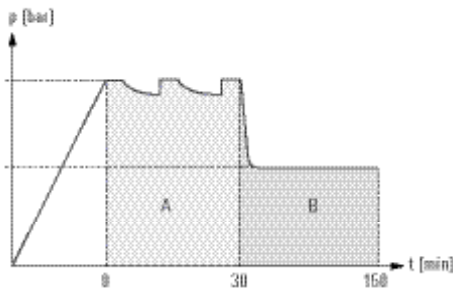

A Adaptation time (repressurise where necessary)

B Pressure test for systems with pipes

1. Build up the test pressure (= 1.1 x max. operating pressure) slowly in the installation
Example test pressure: $1.1 \times 6 \text{ bar (at } 80 \text{ }^\circ\text{C)} = 6.6 \text{ bar}$
2. Maintain the test pressure for 30 minutes. Build up the test pressure again where necessary
3. Note down the test pressure in the pressure test record after 30 minutes
4. Verify the leaktightness of the entire installation, particularly the connecting points, by means of a visual inspection
5. Slowly reduce the test pressure to 0.5 x maximum test pressure and note down the test pressure in the pressure test report
Example reduced test pressure: $0.5 \times 6.6 \text{ bar} = 3.3 \text{ bar}$
6. Read the test pressure after 2 hours and note it down in the pressure test record
7. Verify the leaktightness of the entire installation, particularly the connecting points, by means of a visual inspection

If the test pressure drops away:

- Carry out another precise visual inspection of the pipes, draw-off points and connecting points
- After rectifying the cause of the drop in pressure repeat the pressure test on the system (steps 1-7)
- If no leaks have been found during the visual inspection the leaktightness test can be concluded

Concluding the pressure test with water

Following conclusion of the pressure test:

- The company that performed the test and the client must confirm the pressure test in the pressure test record
- Remove the pressure test device
- Reattach the removed safety and metering equipment

PRESSURE TEST SHEET

Pressure test with water

1. Installation details

Building project: _____

Property owner: _____

Street/House number: _____

Postcode/Town: _____

The filling water is filtered, system fully vented.
The permissible operating pressure is: _____ bar

Water temperature $v_W =$ _____ °C Ambient temperature $v_U =$ _____ °C

$\Delta v = v_U - v_W =$ _____ K

2. Pressure test

Step 1:

$\Delta v \leq 10$ K Ambient temperature to filling temperature

Pressure test _____ bar (1,1 x max. operating pressure,
z. B. 1,1 x 7,6 bar = 8,4 bar)

Wait time _____ min. (min. 30 minutes); maintain the test pressure,
i.e. regularly rebuild

Pressure after 30 min. _____ bar

Complete installation in particular junctions visually checked, no leaks found.

3. Check note

Step 2 of pressure testing found no drop in pressure on the pressure gauge

The complete installation is tight

4. Confirmation

For the customer: _____

For the contractor: _____

Location: _____ Date: _____

Attachments: _____

Request per fax

Have you got projects where you can use CALPEX?

Then copy this page, fill it in and fax it to us. There are many other pipe solutions available on request.

Telefax from:

To:



Brugg Rohrsystem AG

Industriestrasse 39
CH-5314 Kleindöttingen
phone +41 (0)56 268 78 78
fax +41 (0)56 268 78 79

BRUGG Rohrsysteme GmbH

Adolf-Oesterheld-Straße 31
D-31515 Wunstorf
phone +49 (0)50 31 170-0
fax +49 (0)50 31 170-170

Medium: _____ Temperature: _____

Pressure: _____ Flow quantity: _____ ΔT : _____

I would like to receive further information:

Product specification:

- preinsulated
- with leak detection
- with heating cable
- with explosion protection
- double-walled

Laying:

- in the earth
- in the house
- in the installation channel
- under the bridge
- in the tunnel

BRUGG Rohrsysteme file:

Technical information and project references about BRUGG Rohrsysteme

Folder requirement:

PREMANT

rigid pipes, can be used freely in any combination

FLEXWELL

flexibel, self-compensating up to DN 150

CASAFLEX

flexibel, with alarm wires up to DN 100

EIGERFLEX

flexible, frost-protected pipe system

COOLFLEX / COOLMANT

flexible pipe systems for district cooling

Pipe systems for the future

District heating – Industry – Petrol stations – System packages



Your partner for pipe systems

We are the people you should talk to when you need to find efficient solutions for transporting liquid materials. With our project engineers, development department, in-house production unit and our professional team of fitters, we have the know-how and the resources to look after your projects competently and reliably. For all types of heating systems, petrol station construction, industrial plant construction and system packages.

International network

Our global partnership network can be reached on site at any time. More than 34 partners in 20 different countries will look after you wherever you are.

Customer-specific solutions

Brugg is the full service provider in the field of single-wall, double-wall and insulated pipe systems. This know-how allows us to manufacture project-specific customised items.

Give us a call!

Our engineers will be pleased to advise you and find a made-to-measure solution.

Brugg Pipesystems UK Ltd
Kelvin Road
Manor Trading Estate/Benfleet
UK-Essex SS7 4QB
phone +44 (0) 1268 759 567
fax +44 (0) 1268 569 932
sales.uk@brugg.com
www.bruggpipesystems.co.uk

Brugg Rohrsystem AG
Industriestrasse 39
CH-5314 Kleindöttingen
phone +41 (0)56 268 78 78
fax +41 (0)56 268 78 79
pipesystems@brugg.com
www.pipesystems.com

A company of the BRUGG Group